User Manual

S12R

High Speed Centrifuge

Date of Purchase

Serial No.

Place of Purchase

hanil

S12R

Research Use Only

Copyright © 2018 Hanil Scientific Inc. All rights reserved.

Manufacturer : Hanil Scientific Inc.

B2 & 5F, 16 Arayukro, Gochon-eup, Gimpo-si, Gyenggi-do, 13136, Republic of KOREA

Tel) +82-2-3472-0727, Fax) +82-31-985-9158

info@ihantil.com

www.ihantil.com

Contact Us

If you have any questions, contact Hanil Scientific Inc. or place of purchase.

+82-2-3452-8966

Inquiry : Info@ihantil.com

Order : sales@ihantil.com

Tech. support : techsupport@ihantil.com

The appearance or specifications of the device are subject to partial change for improvement.

No part of this manual may be copied or distributed without the manufacturer's permission.

Do not repair or modify the product or its accessories without permission.

UM-S12R(E)(Rev.0)2025.02.06

Original Instruction

CONTENTS

1. Safety warnings and precautions.....	6
1.1. General Considerations	6
1.2. Safety Information	9
1.2.1. Safety label information related to the user manual	9
1.2.2. Safety label information related to the product.....	10
1.2.3. safety level	11
1.2.4. safety message	11
1.3. Electric safety.....	20
1.4. Use Conditions, Storage, Transportation.....	21
2. Product Description	22
2.1. Intended use.....	22
2.2. User Profile	22
2.3. Safety Features Functions.....	22
2.4. Structure	23
2.5. Components	24
2.6. Technical Specifications	25
3. Installation	26
3.1. Unpacking Device	26
3.2. Installation	26
3.2.1. Selecting the location.....	26
3.2.2. Balance Adjustment.....	28
3.3. Power Connection.....	29
3.4. Opening / Closing the Lid	29
3.5. Installing / Removing the rotor	30

3.6. Loading Tubes.....	31
4. Operation.....	33
4.1. Lamp.....	35
4.2. Control panel.....	36
4.3. Rotor Scan	37
4.4. Setting Speed.....	38
4.5. Setting Time.....	39
4.6. Setting Temperature.....	41
4.7. Setting Acceleration / Deceleration.....	42
4.8. Start/Stop	43
4.9. Pulse (Short spin)	44
4.10. Fastcool.....	44
4.11. Changing set value while in operation.....	45
4.12. Setting Lock/Unlock	46
4.13. Indicating Cumulative RCF	46
4.14. Program Setting	47
4.14.1. Program Saving.....	48
4.14.2. Program Delete	48
4.14.3. Program Calling	48
4.14.4. Program Rename.....	49
4.14.5. Program Lock.....	49
4.14.6. Program Unlock.....	50
4.15. Setting.....	50
4.15.1. Multi-Step	50
4.15.2. History.....	55

4.15.3. RPM/RCF Converter	61
4.15.4. General.....	62
4.16. Error Message Display.....	68
5. Maintenance	70
5.1. User Checklist.....	70
5.2. Check the level	71
5.3. Care Instructions for Refrigerated device	71
5.3.1. Open the lid after centrifugation.....	71
5.3.2. Remove the condensation water	72
5.3.3. Remove dust.....	73
5.4. Cleaning and decontamination	74
5.4.1. Cleaning.....	75
5.4.2. disinfection	77
5.4.3. Decontamination of hazardous materials	77
5.5. Emergency Lid Open	78
5.6. Disposal.....	79
6. Troubleshooting	80
6.1. Possible Problems	80
6.2. Error codes	81
7. Rotor & Accessories.....	84

1. Safety warnings and precautions

1.1. General Considerations



Before using this product, be sure to read the user manual carefully and observe all safety precautions. This will help prevent malfunctions that may occur during use.

Centrifuges involve inherent risks due to the use of high-speed rotating components.

Safety precautions are provided to prevent personal injury, product damage, and malfunctions during use. Please follow all safety measures provided in this manual.

Please keep this user manual in a place where it is easily accessible as part of the device.

If you transfer the device to a third party, please also pass on the user manual.

1. Always make sure that the device is fixed on a safe level surface that can withstand shaking and the weight of the device during operation.
 - If the device operates with a tilted shaft, it may cause great vibration and product damage.
2. Do not move the device during operation, and leave a safe space within 30cm around the centrifuge for user safety and surroundings.
 - Ensure there is always enough space around the device for proper air circulation
3. Always install the device in a place where temperature and humidity can be controlled.
4. Before connecting the power, the rated voltage should be checked.

Using the device with an incorrect voltage connection can cause damage to the equipment and pose a risk of personal injury.
5. Use only rotors and recommended parts and accessories provided by Hanil Scientific Inc.

Hanil Scientific Inc. is not responsible for damages to the product or accidents caused by using parts and accessories not recommended.
6. The chamber must always be kept dry before using the centrifuge.
7. Before using the device, make sure that the rotor and rotor lid are securely locked.
 - The rotor must be properly installed and securely locked onto the shaft before use.
 - If the rotor lid detaches during rotation, it can cause significant damage to the product or the sample.
8. Ensure the rotor is securely locked on the motor shaft by manually
9. Do not use your hand to stop the rotor while the device is running.

10. Manual lid opening is only used when rotation is completely stopped.
11. If the density of the entire sample exceeds 1.2 g/mL, the maximum rotation speed should be reduced to prevent rotor overload and rotor damage.
12. sample should be filled up to the recommended volume by tube manufacturer.
Otherwise, the tube may break or the sample solution may leak.
13. To prevent unbalanced rotors, tubes should always be symmetrically loaded with well-balanced (weight, material, density and volume) samples. If necessary, you can use water to achieve symmetry and balance. (Please refer to 4.3 Sample Tube Loading)
14. The operating speed should not be higher than the individual maximum g-values of the centrifuge, rotor, bucket or adapter and sample tube. In particular, the maximum g-value of the sample tube should not be neglected.
15. The rotor should be cleaned and dried after each use for long life and safety.
16. The rotor must be handled with care as it can corrode when exposed to cleaning agents like strong acids, strong bases, cesium, silver, or salts.
17. Turn off the power switch after using the device.
18. Always disconnect the power supply during long periods of non-use, cleaning, regular maintenance, or servicing to avoid electric shock.
19. After centrifugation of biological materials, follow validated disinfection procedures.
20. Do not centrifugation flammable, toxic, radioactive, explosive, or corrosive substances.
21. Do not use the product in environments where there is a risk of explosion or fire.
22. If it is necessary to use toxic or radioactive substances or pathogenic microorganisms belonging to WHO Risk Group II, the national regulations of the "Laboratory Bio-safety Manual" must be observed.
23. Ensure that the ventilation hole is not obstructed.
24. Do not insert any objects into the device openings.
25. Do not detach the lid or protective cover using tools.
26. When requesting repairs, users must remove any contaminants beforehand.
27. Repairs and maintenance must be performed by a technician certified by Hanil Scientific Inc.









28. Please contact the supplier for product repairs.

29. Equipment damage can occur in the following scenarios, and the user is liable for any damages or injuries that arise.:

- not using the device in accordance with the user manual's instructions.
- Using the product for purposes other than its intended use.
- Using unauthorized accessories and tools.
- Unauthorized personal maintenance, repair, and modification.







1.2. Safety Information

1.2.1. Safety label information related to the user manual



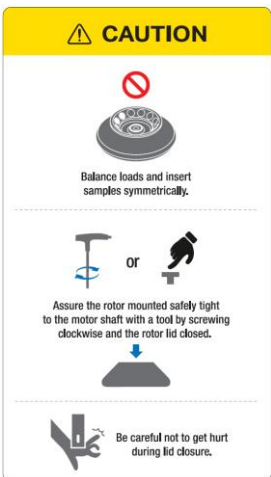

Label	Information
	Mark indicating danger and warning
	Attention and warning for electric shock
	Mark indicating biological hazard
	Mark indicating explosion warning
	Mark indicating crushing of hands
	Disconnect the electrical plug from the socket
	Refer to the user manual
	Wear protective gloves
	Wear safety shoes

1.2.2. Safety label information related to the product



Users should not remove any labels attached to this unit without permission.









Label	Information
	<p>Mark indicating danger and warning</p>
	<p>Attention and warning for electric shock</p>
	<p>Mark indicating biological hazard</p>
	<p>Mark indicating crushing of hands</p>
	<p>Mark indicating earth grounding</p>
	<p>Mark manual lid open hole and rotation direction</p>
	<p>Rotor insertion, sample loading and lid closing caution sign</p>





1.2.3. safety level







Label and color	Information
	<p>Danger!</p> <p>A hazardous situation which can result in death or serious injury.</p>
	<p>Warning!</p> <p>A potentially hazardous situation which can result in serious injury.</p>
	<p>Caution!</p> <p>A potentially hazardous situation which can result in minor injury.</p>
	<p>Note</p> <p>It contains important information regarding the use and damage of the equipment.</p>









1.2.4. safety message





	<p>Danger!</p>
	<p>Risk of electric shock or fire due to failure to check product ratings.</p> <ul style="list-style-type: none"> • Ensure that the device rating matches the rating you ordered, and the power cable is suitable for the device's power socket and the service environment. Incorrect connection may cause electric shock or fire. If the product is different from the ordered specifications, please contact your place of purchase.
	<p>Risk of electric shock due to incorrect power connection.</p> <ul style="list-style-type: none"> • Use only the power cable provided with the device. • Plug the power plug into a grounded outlet. Contact your facility's maintenance team or an electrical professional to ensure that the outlet is grounded. • If using a power strip, connect the product after checking the grounding and rated capacity. • Install the device so that the power cable cannot be stepped on. • Do not place anything on the power cable.



	<p>Danger!</p>
  	<p>Precautions when using, storing, and transporting the product.</p> <ul style="list-style-type: none"> • Before storing the device, clean and store the device and accessories according to the management procedures. Otherwise, problems with the performance and stability of the product and accessories may occur. • Before storing or transporting, turn off the power to the product and close the lid. • Before transporting this product, remove the rotor if there is an installed one. Otherwise, the motor shaft may be damaged by the vibration generated when transporting the product. • When carrying the product, there is a risk of injury, so wear personal protective equipment. • Refrigerated centrifuges must be transported carefully due to their off-center gravity. • Maintain balance while transporting to avoid damage to the device and its components from impacts. • The weight of this device (without rotor) is 227 kg, and there is a risk of injury when carrying it without external help.
	<p>Do not install in environments with explosion or fire hazard.</p> <ul style="list-style-type: none"> • Do not install the device in environments where explosions or fires could occur. • Do not place the device near any materials that may generate a flammable or explosive atmosphere.
	<p>Risk of product damage due to liquid permeation.</p> <ul style="list-style-type: none"> • Be careful to prevent liquids from entering the device, as this can damage electrical, electronic, and mechanical components. • Do not place containers filled with liquids on top of or near the product.
 	<p>Risk of electric shock if the power is not disconnected.</p> <ul style="list-style-type: none"> • Before cleaning the device, ensure it has completely stopped, then turn off all power sources, and unplug the product from the electrical outlet.
	<p>Risk of electric shock due to skipped drying.</p> <ul style="list-style-type: none"> • After cleaning, washing, and removing any contamination, ensure all parts of the device are completely dry before connecting the power source.









	Danger!
 	<p>Before washing, guidance.</p> <ul style="list-style-type: none"> • The product should be placed on a flat surface before cleaning or washing. • When moving the device to another location, clean and disinfect both the exterior and interior before relocation. • Put on appropriate personal protective equipment before cleaning or decontaminating. • When performing tasks such as cleaning, disinfecting, or decontamination, follow the safety regulations of your institution.
	<p>Before return the device, guidance.</p> <ul style="list-style-type: none"> • When returning products or parts for service, repair, or disposal, disinfect or remove any contaminants. • Be sure to fill out a "Decontamination Confirmation Form" and send it together with the device. The "Decontamination Confirmation Form" can be downloaded from the Documents section of the SUPPORT tab on the www.ihanil.com website.
	<p>Risk of component damage due to exceeding sterilization tolerances.</p> <ul style="list-style-type: none"> • When sterilizing by high-pressure steam, do not exceed the specified temperature and time limits (121°C, 20 minutes). Exceeding the tolerances may result in component deformation or device malfunction.



	Warning!
	<p>Risk due to pathogenic, infectious, toxic, and radioactive materials.</p> <ul style="list-style-type: none"> • When handling pathogenic, infectious, toxic, and radioactive materials, observe laboratory biosafety guidelines, applicable national regulations, and the Material Safety Data Sheet (MSDS). • If the material belongs to risk group II, refer to the Laboratory Biosafety Manual. • When handling hazardous materials, wear personal protective equipment. • If the centrifuge becomes contaminated with pathogenic, toxic, or radioactive materials, the contaminated material must be thoroughly removed, and necessary measures such as ventilation or isolation must be taken. • If safety measures are not taken, accidents of infection, poisoning, and radioactive exposure may occur.
	<p>Risk of damage to products and parts due to mechanical or chemical damage.</p> <ul style="list-style-type: none"> • Do not use damaged, cracked, or corroded products or parts. • Do not use corrosive chemicals such as strong bases, weak bases, strong acids, cesium, silver, mercury, other heavy metals, phenol, formaldehyde, etc. • If the device or accessories are contaminated, turn off the power immediately and clean it. • Organic solvents may cause damage to the rotor. • After using organic solvents, immediately clean the accessories and the device used.
	<p>Risk of product damage or accident if the product is impacted or moved during operation.</p> <ul style="list-style-type: none"> • Do not move the product while it is in operation. • Do not lean or place objects on the product while it is in operation. • The device gets impacted during operation or movement, which may cause device damage or accidents.
	<p>Risk of electric shock due to damage to the product and power cord.</p> <ul style="list-style-type: none"> • Use a complete product with no external or internal damage. • Do not use a damaged or worn-down power cord.
	<p>Risk of electric shock due to damaged housing.</p> <ul style="list-style-type: none"> • Check the condition of the device housing before connecting to power. If the device housing is damaged or incomplete, there is a risk of electric shock due to high voltage inside. Please contact your supplier or the service team of Hanil Scientific Inc.







	Warning!
	<p>Risk of crushing when opening and closing the lid.</p> <ul style="list-style-type: none"> • When opening and closing the lid, be careful of your fingers. • After closing the lid, you must double-check the closed state. • The device will not start working unless the lid is closed. • When opening the lid, ensure it is fully opened so that it does not close back to its original position.
	<p>Risk of injury from spinning rotor.</p> <ul style="list-style-type: none"> • Do not contact the spinning rotor with your hands or tools. • Do not open the lid or release the lid lock system while the rotor spins.
	<p>Damage to the rotor due to incorrect rotor handling.</p> <ul style="list-style-type: none"> • Do not lift the rotor by holding the angle rotor lid. The rotor may fall, causing rotor damage or injury. • Always use both hands when handling the rotor. • Check the rotor weight, and do not handle some heavy rotors alone.
	<p>Product damage and risk of injury from loose rotors.</p> <ul style="list-style-type: none"> • If the rotor is not tightened securely or installed correctly, Significant vibration and noise may occur. • Stop using the device immediately if you notice severe vibrations or noise.
	<p>Precaution when installing the rotor.</p> <ul style="list-style-type: none"> • Be sure to install a fit tube type that matches the rotor hole shape (diameter, height, bottom shape).
	<p>Disconnect the power after stopping operation.</p> <ul style="list-style-type: none"> • Before opening the lid in an emergency, be sure to turn off all power and unplug the cable from the outlet after the device has stopped working.
	<p>Risk of injury and sample damage when opening the lid manually.</p> <ul style="list-style-type: none"> • Manual lid opening must be performed after the machine has completely stopped rotating. Failure to follow this may result in damage to the sample or the user. • Do not close the lid immediately after the emergency opening. Wait for the power to be restored before using the device normally. • Only use the manual lid open in an emergency.





	Warning!
	<p>Risk of damage due to a defective lid shock absorber.</p> <ul style="list-style-type: none"> • We recommend that you check the lid shock absorber every two years. • Open the lid completely and make sure it is secured. • If you have any problems with the lid shock absorber, contact the service team of Hanil Scientific Inc.
	<p>Risk of crushing when opening and closing the ventilation.</p> <ul style="list-style-type: none"> • When opening and closing the ventilation, be careful of your fingers. • After closing the ventilation, you must double-check the closed state.
	<p>Risk of product damage due to insufficient or belated maintenance.</p> <ul style="list-style-type: none"> • Follow the maintenance cycles and procedures recommended by the manufacturer. • Select the disinfection method under applicable laboratory and legal regulations. • When performing maintenance, check that the device and parts are not damaged or defective. • Perform regular inspections of electrical safety, a device, parts, etc. at least every 12 months at an official service center of Hanil Scientific Inc. • Contact us for information on main body parts and consumables. • Dust accumulation in the vent may cause device failure or fire.

	Caution!
	<p>Risk of sample damage from heated parts.</p> <ul style="list-style-type: none"> • Make sure that the temperature control performance of the centrifuge matches the sample specifications. • For refrigerated centrifuges, you can set the temperature. Depending on the rotor and rotation speed, there may be a variation between the set temperature and the sample temperature. • If the sample temperature is important, proceed with the test and check it before use.
	<p>Risk of injury due to product movement.</p> <ul style="list-style-type: none"> • Do not lean on the product. If not, the device can collide with the surrounding products or cause injury.







	Caution!
	<p>Risk of product damage due to imbalance.</p> <ul style="list-style-type: none"> • After placing the device on a flat and firm surface, balance adjustment must be performed. • If the product is installed imbalanced, it may cause vibration, noise, and failure.
	<p>Risk of crushing hands when installing the rotor.</p> <ul style="list-style-type: none"> • When installing or removing the rotor, be careful with your hands.
	<p>Precautions when inserting the sample tubes.</p> <ul style="list-style-type: none"> • If the density of the entire sample exceeds 1.2 g/mL, the maximum rotation speed should be reduced to prevent rotor overload and rotor damage.
	<p>Risk of product damage due to tube overloading.</p> <ul style="list-style-type: none"> • Use only tubes designed specifically for centrifuges. • Check the maximum RCF (g-force) value for each tube specified by the tube manufacturer and do not use more than the maximum RCF (g-force). • Always fill to the capacity specified by the tube manufacturer. • If no allowable capacity is provided, fill the tubes to a level where the centrifuged contents do not spill out.
	<p>Risk of injury from deformed or open tubes</p> <ul style="list-style-type: none"> • Tubes may be deformed or damaged due to autoclaves, organic solvents, etc. • Check the condition of the tubes before using them. • Do not use the deformed or damaged tubes. • Tightly seal all tube covers before use.
	<p>Risk of product damage and injury due to breakage when using glass tubes.</p> <ul style="list-style-type: none"> • Glass tubes may break during centrifugation, causing glass fragments to scatter or be contaminated. • When cleaning broken tubes, wear appropriate personal protective equipment and remove them.
	<p>Risk of shaft damage due to non-horizontal.</p> <ul style="list-style-type: none"> • If the product is not in a level position, it may cause imbalance or damage to the motor shaft.
	<p>Do not use metal-based cleaning tools.</p> <ul style="list-style-type: none"> • Do not use the metal scrubbing or wire brush. This will peel off the product coating and cause corrosion.

	Caution!
	<p>Risk of injury and product damage due to the use of unauthorized accessories and spare parts.</p> <ul style="list-style-type: none"> Use only provided the rotors, parts, and accessories by Hanil Scientific Inc. Hanil Scientific Inc. is not responsible for damages to the device or accidents caused by using parts and accessories not recommended.

	Note!
	<p>Risk of product damage due to condensation.</p> <ul style="list-style-type: none"> If When moving the device from a cold environment to a warm environment, condensation can occur and damage electronic components. Ensure the device is fully dry at room temperature for a minimum of 4 hours before referring to [3.3 Power Connection] for connection instructions.
	<ul style="list-style-type: none"> When you receive the device, carefully check the appearance of the packaging to ensure that it has not been damaged during transportation on a flat surface where the product will not slip. If the product packaging is damaged, please get in touch with the supplier immediately. Contact information can be found at the bottom of the user manual and on the label affixed to the product.
	<ul style="list-style-type: none"> The device should be installed so that the power switch, plug, and outlet are easily accessible to the user.
	<p>Electrical requirements</p> <ul style="list-style-type: none"> The rated voltage is 220-240 V~, and if the voltage varies by more than $\pm 10\%$ from the standard voltage, it may affect the device's precision and reliability. Ensure a stable power supply to avoid damage to the various components inside the centrifuge. This device is used with a 220-240 V~ rated voltage.
	<p>[Sample weight imbalance detection] system</p> <ul style="list-style-type: none"> The centrifuge includes a safety feature that detects imbalances due to significant differences in sample weight and forces an automatic stop to protect both the device and user.

	Note!
	<p>Check Rotor connection</p> <ul style="list-style-type: none"> • Before use, make sure that the rotor is securely fastened to the motor shaft. <p>Check Rotor Lid installation</p> <ul style="list-style-type: none"> • If you operate a fixed angle rotor, make sure that the rotor lid is properly locked. If not, it may cause very loud noise and serious damage.
	<p>Manual lid open</p> <ul style="list-style-type: none"> • When the lid cannot be opened automatically and the device is not powered, samples can be removed from the rotor using this method.
	<p>Close the drain cap</p> <ul style="list-style-type: none"> • Please close the drain cap after fully tightening before using the device. • Operating with the drain cap is not fully closed, cooling air is discharged to the outside through the drain hoe, which reduces cooling efficiency.
	<p>Do not store bleach</p> <ul style="list-style-type: none"> • Use freshly made 10% bleach for disinfection each time. • Bleach loses its effectiveness after 24 hours when diluted with water, so use it immediately without storing it.







1.3. Electric safety

	Danger!
	<p>Risk of electric shock or fire due to failure to check product ratings.</p> <ul style="list-style-type: none"> • Ensure that the device rating matches the rating you ordered, and the power cable is suitable for the device's power socket and the service environment. Incorrect connection may cause electric shock or fire. If the product is different from the ordered specifications, please contact your place of purchase.
	<p>Risk of electric shock due to incorrect power connection.</p> <ul style="list-style-type: none"> • Use only the power cable provided with the device. • Plug the power plug into a grounded outlet. Contact your facility's maintenance team or an electrical professional to ensure that the outlet is grounded. • If using a power strip, connect the product after checking the grounding and rated capacity. • Install the device so that the power cable cannot be stepped on. • Do not place anything on the power cable.
	Warning!
	<p>Risk of electric shock due to damage to the product and power cord.</p> <ul style="list-style-type: none"> • Use a complete product with no external or internal damage. • Do not use a damaged or worn-down power cord.
	Note!
	<p>Risk of product damage due to condensation.</p> <ul style="list-style-type: none"> • If When moving the device from a cold environment to a warm environment, condensation can occur and damage electronic components. Ensure the device is fully dry at room temperature for a minimum of 4 hours before referring to [3.3 Power Connection] for connection instructions.

1. If you have the following emergencies, shut off the power supply and unplug the power cord from outlet and contact your place of purchase or Hanil Scientific Inc.

- Unusual noises or smell from the device.
- Damage or wear on a power cord.
- Breakdown of circuit breaker, fuse or safety device.
- If you spill liquid on the device.
- If the device is damaged.

1.4. Use Conditions, Storage, Transportation

	Danger!
  	<p>Precautions when using, storing, and transporting the product.</p> <ul style="list-style-type: none"> • Before storing the device, clean and store the device and accessories according to the management procedures. Otherwise, problems with the performance and stability of the product and accessories may occur. • Before storing or transporting, turn off the power to the product and close the lid. • Before transporting this product, remove the rotor if there is an installed one. Otherwise, the motor shaft may be damaged by the vibration generated when transporting the product. • When carrying the product, there is a risk of injury, so wear personal protective equipment. • Refrigerated centrifuges must be transported carefully due to their off-center gravity. • Maintain balance while transporting to avoid damage to the device and its components from impacts. • The weight of this device (without rotor) is 227 kg, and there is a risk of injury when carrying it without external help.
	Caution!
	<p>Risk of injury due to product movement.</p> <ul style="list-style-type: none"> • Do not lean on the product. If not, the device can collide with the surrounding products or cause injury.

Use Conditions

Usage Environment	Indoor
Indoor Temperature	5 to 40°C
Relative Humidity	Maximum relative humidity of 80% (non-condensing)
Pressure	500 to 1,060 hPa
Maximum Altitude	2,000 m
Overvoltage Category	II
Pollution Degree	2

Storage & Transportation

Ambient Temperature	-18 to 40°C
Humidity	10 ~ 90%

2. Product Description

2.1. Intended use

This device is a centrifugal separation device used for separating samples through centrifugal force. It should be operated by trained and skilled professionals in laboratory-scale indoor settings.

2.2. User Profile

This device must be operated by a professional who has received professional education, training, and specialized skills for the using procedure.

2.3. Safety Features Functions

- Rotor recognition system

Recognize the rotor, limit the settable speed to operate safely within acceptable speed values, and allow automatic calculations when converting rpm ↔ rcf.

- Imbalance detection system

Detects sample imbalance through the imbalance detection system built into the device.

Operation is forcibly halted when an imbalance is detected.

This prevents any risks that may occur from operating an unbalanced sample.

- Lid open and close detecting system

Detect the opening and closing of the lid to prevent the device from operating with the lid open.

When the device starts operating, the lid button is disabled to prevent the lid from opening.

- Error alarm

If a problem occurs with the device, an error code displays with a sound.

Detailed error codes are in [6.2. Error codes].

- Apply steel frame

The chamber is installed in a steel frame, and the inside of the lid is also made of steel plate to prevent damage that occurs inside the chamber from being ejected externally.

2.4. Structure

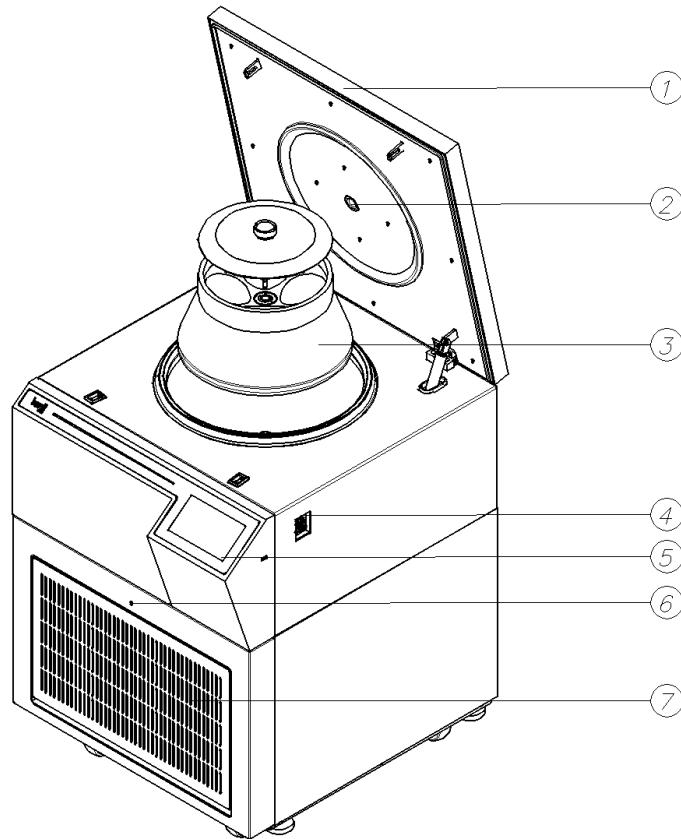

- ① Lid: Protects the internal chamber and samples, preventing the rotor from detaching in case of danger.
 - ② RPM measuring window : Measure the rotor speed with digital tachometers and similar devices.
 - ③ Rotor : It is a rotating body that rotates by loading a tube. (Optional).
 - ④ Power Switch : Turn the device ON/OFF after connecting the power.
 - ⑤ Control Panel : Input and verify various centrifugation settings (rpm, temperature, time ,etc.).
 - ⑥ Manual Lid Open Hole : Open the lid in case of an emergency.
 - ⑦ Ventilation Slots : It is a vent installed in the section where the compressor is integrated.
- ※ Rotor sold separately (refer to 7. Rotor & accessories)

2.5. Components

① Basic Components

- Main unit of the device
- Power cable
- User manual
- Manual Lid Open Tool(T-wrench)
- The leveler

② Additional optional products



- Refer to [7. Rotor & Accessories]

2.6. Technical Specifications

Max. RPM	12,000 rpm
Max. RCF	22,265 xg
Time control	< 100 hr, continuous, pulse
Max. Capacity	6 x 1,000 mL
Temperature range	-10°C to 40°C
ACC/DEC steps	10 /11 steps
Program memory	100
Rotor Identification	Automatic
Imbalance cutoff / tracking	Yes
Noise level	< 65 dB
Dimension (W x D x H, mm)	681 x 795 x 920
Weight	227 kg
Power requirement	3,800 VA
Ratings	220-230 V~, 50/60 Hz

3. Installation

3.1. Unpacking Device

	Note!
	<ul style="list-style-type: none"> • When you receive the device, carefully check the appearance of the packaging to ensure that it has not been damaged during transportation on a flat surface where the product will not slip. • If the product packaging is damaged, please get in touch with the supplier immediately. • Contact information can be found at the bottom of the user manual and on the label affixed to the product.





1. After purchasing the centrifuge, open the packaging and verify the contents of the components.
 - ▶ Refer to [2.5. Components] to check the list of components.
 - ▶ Please retain the product packaging instead of disposing of it. The packaging should be used for transportation or storage of the device.
2. Please contact the place of purchase or service center if any components are missing.

3.2. Installation

3.2.1. Selecting the location

Only certified companies and personnel from Hanil Scientific Inc. are authorized to install the device.

Please verify and comply with the following guidelines during installation.

	Note!
	<ul style="list-style-type: none"> • The device should be installed so that the power switch, plug, and outlet are easily accessible to the user.
	Danger!
	<p>Do not install in environments with explosion or fire hazard.</p> <ul style="list-style-type: none"> • Do not install the device in environments where explosions or fires could occur. • Do not place the device near any materials that may generate a flammable or explosive atmosphere.

1. Installation on hard and flat ground.

- ▶ Centrifuge should be installed on hard and flat place.
- ▶ If the centrifuge is installed in an inclined place, the shaft can be bent due to the weight of the rotor.

2. Install it in a location where smooth ventilation is possible.

- ▶ Keep at least 30 cm of space around the device for safe use.

3. Constant temperature/humidity

- ▶ Centrifuge equipped with sensitive electronic components which is fragile with humidity and temperature. Please refer to [1.4 Use Conditions, Storage, Transportation] for information regarding temperature and humidity.
- ▶ Do not expose the device or accessories to direct sunlight.
- ▶ Do not install near heat-generating equipment. Warm air causes the motor to overheat, and the cooling efficiency may decrease when warm air flows in.



4. Avoid the corrosive gas

- ▶ Install the centrifuge in a place where corrosive gas is not generated.
- ▶ Do not place any materials that can generate flammable or explosive vapors nearby.

5. Avoid installing the device in areas with electromagnetic radiation.

- ▶ Do not expose the device or accessories to an environment or near equipment that generates electromagnetic radiation. This may reduce the performance and stability of the device and accessories.

3.2.2. Balance Adjustment

	Caution!
	<p>Risk of product damage due to imbalance.</p> <ul style="list-style-type: none"> • After placing the device on a flat and firm surface, balance adjustment must be performed. • If the product is installed imbalanced, it may cause vibration, noise, and failure.

1. Place the device on a hard and flat surface.

2. Put the leveler tool on the device.





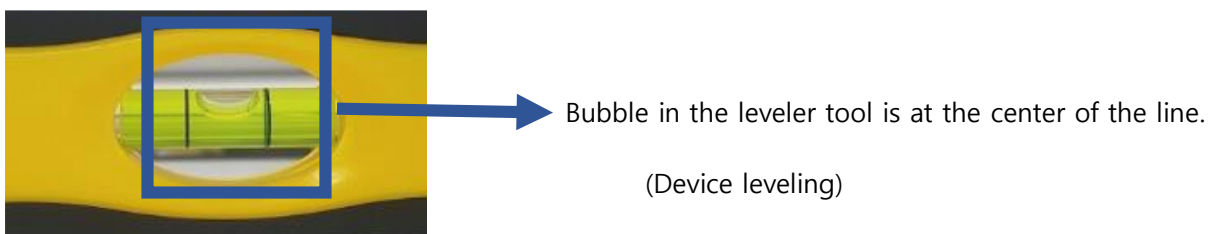
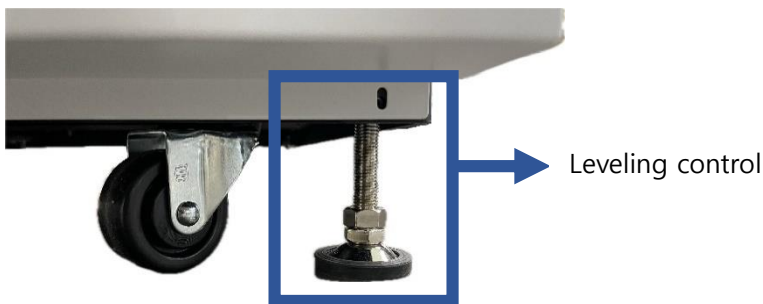

3. Turn the four leveling controls on the bottom of the device to ensure level.

Refer to [3.5. Installing / Removing the rotor] to install the rotor, and then complete the final balancing operation.





3.3. Power Connection

	Warning!
	<p>Risk of electric shock due to damaged housing.</p> <ul style="list-style-type: none"> Check the condition of the device housing before connecting to power. If the device housing is damaged or incomplete, there is a risk of electric shock due to high voltage inside. Please contact your supplier or the service team of Hanil Scientific Inc.
	Note!
	<p>Electrical requirements</p> <ul style="list-style-type: none"> The rated voltage is 220-240 V~, and if the voltage varies by more than $\pm 10\%$ from the standard voltage, it may affect the device's precision and reliability. Ensure a stable power supply to avoid damage to the various components inside the centrifuge. This device is used with a 220-240 V~ rated voltage.

1. Plug the power cable into the power socket, then connect the plug to the outlet.

2. Press the power switch [ON/OFF] to turn on [ON] the power.

3.4. Opening / Closing the Lid

	Warning!
	<p>Risk of crushing when opening and closing the lid.</p> <ul style="list-style-type: none"> When opening and closing the lid, be careful of your fingers. After closing the lid, you must double-check the closed state. The device will not start working unless the lid is closed. When opening the lid, ensure it is fully opened so that it does not close back to its original position.
	<p>Risk of injury from spinning rotor.</p> <ul style="list-style-type: none"> Do not contact the spinning rotor with your hands or tools. Do not open the lid or release the lid lock system while the rotor spins.





[Opening the Lid]

1. Press the lid button while the power is connected.

[Closing the Lid]

1. After lowering the lid, please firmly close it with both hands.



3.5. Installing / Removing the rotor

	Warning!
	<p>Damage to the rotor due to incorrect rotor handling.</p> <ul style="list-style-type: none"> • Do not lift the rotor by holding the angle rotor lid. The rotor may fall, causing rotor damage or injury. • Always use both hands when handling the rotor. • Check the rotor weight, and do not handle some heavy rotors alone.
	<p>Product damage and risk of injury from loose rotors.</p> <ul style="list-style-type: none"> • If the rotor is not tightened securely or installed correctly, Significant vibration and noise may occur. • Stop using the device immediately if you notice severe vibrations or noise.
	Caution!
	<p>Risk of crushing hands when installing the rotor.</p> <ul style="list-style-type: none"> • When installing or removing the rotor, be careful with your hands.



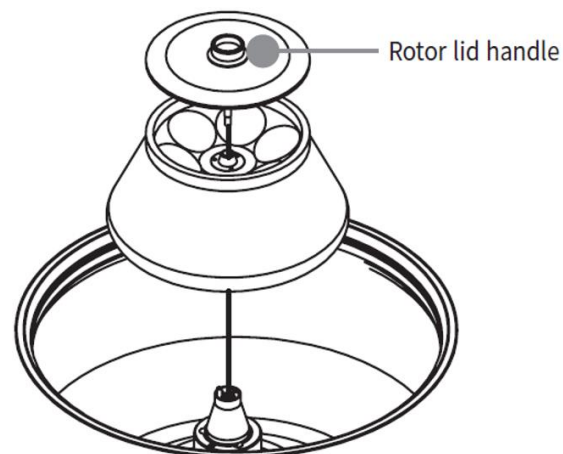



When removing or replacing the rotor, please follow the steps below;

1. Before installing the rotor, use a dry cloth to remove any foreign material or moisture from the motor shaft and rotor.
2. Insert the rotor into the motor shaft.
3. Place the rotor lid on the rotor body.
4. Tighten the rotor lid handle clockwise. (Tighten the rotor lead handle all the way until it cannot be returned.)
 - ▶ Installing the rotor: Rotate clockwise.
 - ▶ Removing the rotor: Rotate counterclockwise
5. Check that the rotor is securely fastened to the motor shaft.
6. After installing the rotor, place the leveler over the top center of the rotor, making sure the bubble inside the leveler are level.



	Note!
	<p>Check Rotor connection</p> <ul style="list-style-type: none"> • Before use, make sure that the rotor is securely fastened to the motor shaft. <p>Check Rotor Lid installation</p> <ul style="list-style-type: none"> • If you operate a fixed angle rotor, make sure that the rotor lid is properly locked. If not, it may cause very loud noise and serious damage.

3.6. Loading Tubes

	Warning!
	<p>Precaution when installing the rotor.</p> <ul style="list-style-type: none"> • Be sure to install a fit tube type that matches the rotor hole shape (diameter, height, bottom shape).
	Caution!
	<p>Precautions when installing the sample tubes.</p> <p>If the density of the entire sample exceeds 1.2 g/mL, the maximum rotation speed should be reduced to prevent rotor overload and rotor damage.</p>
	<p>Risk of product damage due to tube overloading.</p> <ul style="list-style-type: none"> • Use only tubes designed specifically for centrifuges. • Check the maximum RCF (g-force) value for each tube specified by the tube manufacturer and do not use more than the maximum RCF (g-force). • Always fill to the capacity specified by the tube manufacturer. • If no allowable capacity is provided, fill the tubes to a level where the centrifuged contents do not spill out.
	<p>Risk of injury from deformed or open tubes</p> <ul style="list-style-type: none"> • Tubes may be deformed or damaged due to autoclaves, organic solvents, etc. • Check the condition of the tubes before using them. • Do not use the deformed or damaged tubes. • Tightly seal all tube covers before use.
	<p>Risk of product damage and injury due to breakage when using glass tubes.</p> <ul style="list-style-type: none"> • Glass tubes may break during centrifugation, causing glass fragments to scatter or be contaminated. • When cleaning broken tubes, wear appropriate personal protective equipment and remove them.

1. Before loading sample tubes, check the water drop or any dirt in the rotor hole.

- ▶ If there is any foreign matter or moisture, remove it with soft dry cloth.

2. Tubes should be symmetrically inserted with well-balanced (weight, material, density, and volume) samples. If an appropriated balance is not provided, unexpected accidents can result from a damaged rotor or centrifuge.



- ▶ Ensure that only centrifuge-compatible tubes are used, verify the maximum RCF values provided by the tube manufacturer, and do not use them beyond the specified limits.
- ▶ sample should be filled up to the recommended volume by tube manufacturer.

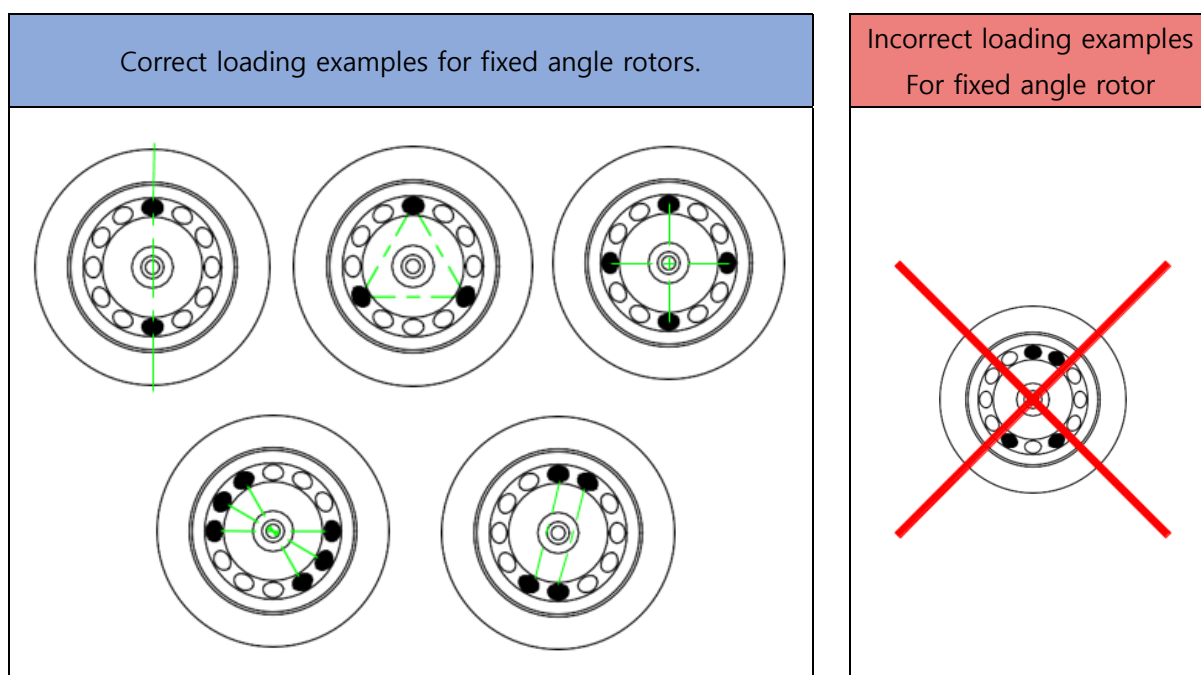

if the manufacturer of the tube has not specified the maximum level, fill the tubes so that the centrifuged substance does not run out of the vessel during centrifugation.







	<p>Note!</p>
	<p>[Sample weight imbalance detection] system</p> <ul style="list-style-type: none"> • The centrifuge includes a safety feature that detects imbalances due to significant differences in sample weight and forces an automatic stop to protect both the device and user.

4. Operation

	Danger!
	<p>Risk of product damage due to liquid permeation.</p> <ul style="list-style-type: none"> • Be careful to prevent liquids from entering the device, as this can damage electrical, electronic, and mechanical components. • Do not place containers filled with liquids on top of or near the product.

	Warning!
	<p>Risk due to pathogenic, infectious, toxic, and radioactive materials.</p> <ul style="list-style-type: none"> • When handling pathogenic, infectious, toxic, and radioactive materials, observe laboratory biosafety guidelines, applicable national regulations, and the Material Safety Data Sheet (MSDS). • If the material belongs to risk group II, refer to the Laboratory Biosafety Manual. • When handling hazardous materials, wear personal protective equipment. • If the centrifuge becomes contaminated with pathogenic, toxic, or radioactive materials, the contaminated material must be thoroughly removed, and necessary measures such as ventilation or isolation must be taken. • If safety measures are not taken, accidents of infection, poisoning, and radioactive exposure may occur.
	<p>Risk of damage to products and parts due to mechanical or chemical damage.</p> <ul style="list-style-type: none"> • Do not use damaged, cracked, or corroded products or parts. • Do not use corrosive chemicals such as strong bases, weak bases, strong acids, cesium, silver, mercury, other heavy metals, phenol, formaldehyde, etc. • If the device or accessories are contaminated, turn off the power immediately and clean it. • Organic solvents may cause damage to the rotor. • After using organic solvents, immediately clean the accessories and the device used.

	Warning!
	Risk of product damage or accident if the product is impacted or moved during operation. <ul style="list-style-type: none">• Do not move the product while it is in operation.• Do not lean or place objects on the product while it is in operation.• The device gets impacted during operation or movement, which may cause device damage or accidents.

	Caution!
	Risk of sample damage from heated parts. <ul style="list-style-type: none">• Make sure that the temperature control performance of the centrifuge matches the sample specifications.• For refrigerated centrifuges, you can set the temperature. Depending on the rotor and rotation speed, there may be a variation between the set temperature and the sample temperature.• If the sample temperature is important, proceed with the test and check it before use.

4.1. Lamp



- A lamp is installed on the front of the instrument, and the color of the lamp changes according to the device operating status.
- The lamp can be turned off through the menu, and for instructions on how to turn off the lamp, please refer to the [4.15.4.2. Lamp Control].
- Even if the lamp is turned off in the menu, it still turns on as Lamp Rotation during device booting.

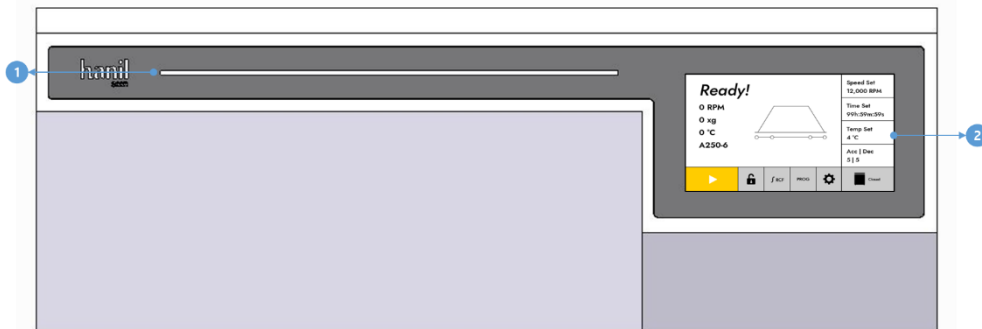

<Figure 1. Front Panel>

#	Item	Description
1	Lamp	The lamp for indicates the operating status of the device through color.
2	Display	A display for adjusting the settings and operations of the device.

#	Color	Device status
1	White	Device Booting
2	Blue	Standby
3	Green Blink	Acceleration
4	Green	Speed Maintenance
5	Yellow Blink	Deceleration
6	Yellow	Lid Open
7	Red Blink	Error Occurred

4.2. Control panel

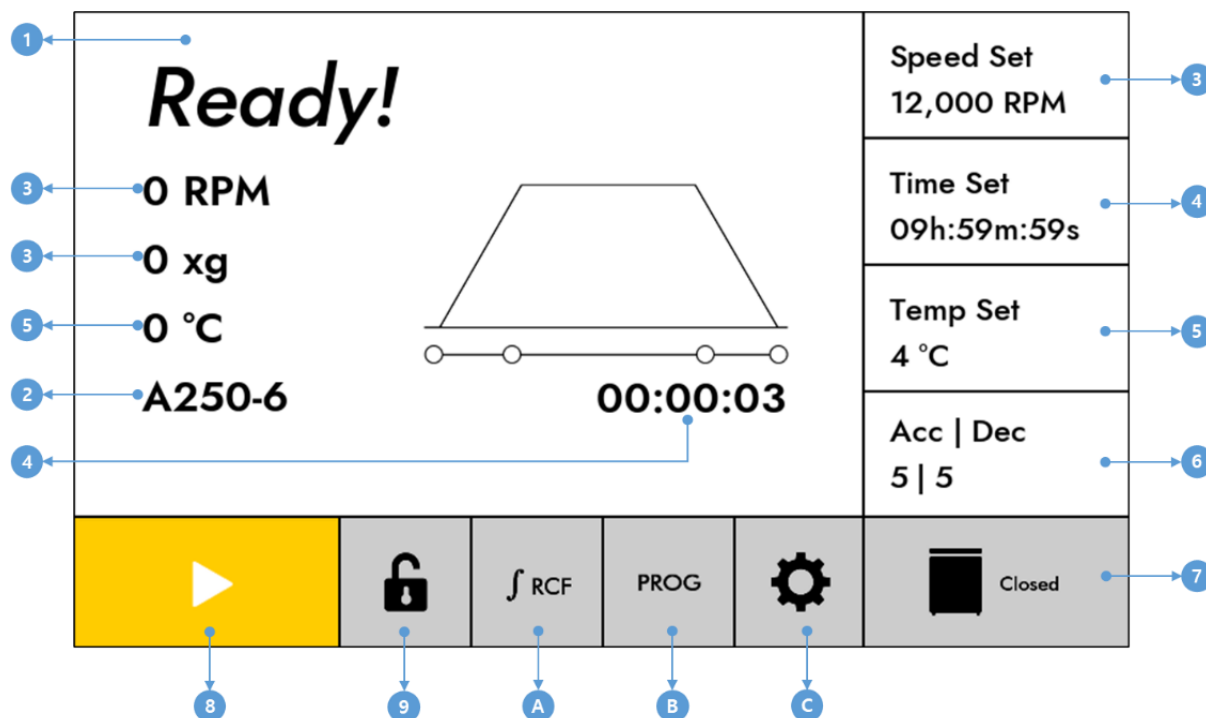

<Figure 2. Main display>

#	Button	Description
1	Display	Check the current values of speed, time, temperature, rotor, etc.
2	Rotor Name	Check the installed rotor name.
3	Speed	Move to the screen for setting the RPM.
4	Time	Move to the screen for setting the centrifugation time.
5	Temp	Move to the screen for setting the temperature inside the chamber.
6	Acc Dec	Move to the screen to change the acceleration/deceleration steps
7	Lid Open	Open the lid.
8	Start/Stop	Use to start and stop operation.
9	Lock/Unlock	Lock or unlock the screen to prevent button selection.
A	Accumulated RCF	Check the accumulated RCF value while pressing the button. (Display the current RCF value in area ①.)
B	Program	Move to the screen for saving, deleting, or calling programs.
C	Setting	Move to the screen for adjusting settings.

4.3. Rotor Scan

The rotor installed in the instrument is automatically recognized.

Rotor recognition occurs automatically under the following two conditions:

- 1) When the power is turned on with the lid closed.
- 2) When the lid is opened and then closed while the power is on.

During Rotor Scan, the following image is displayed:

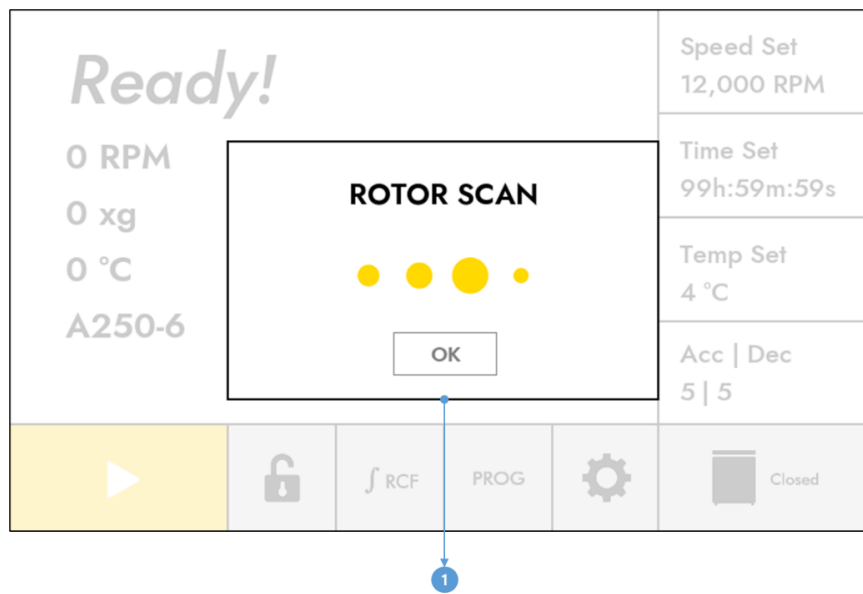

<Figure 3. Rotor Scan Display>

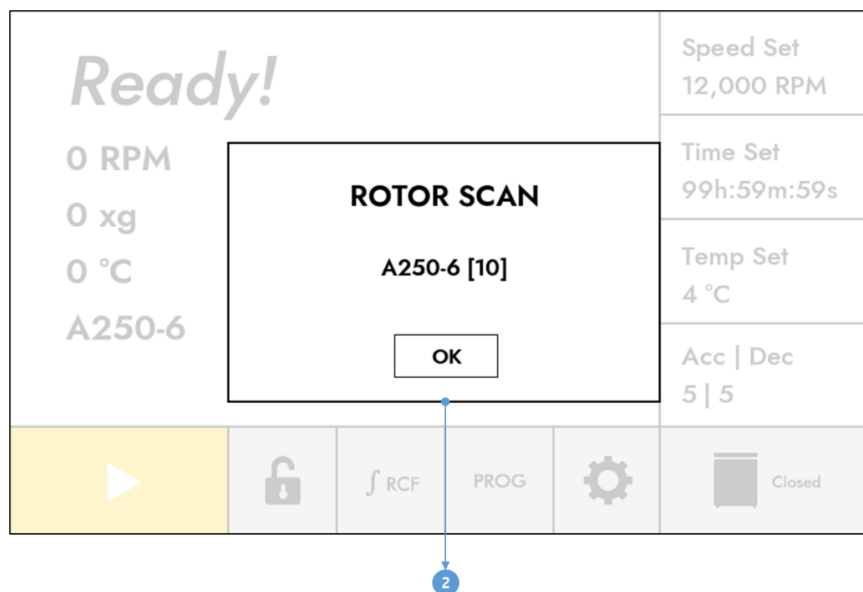

<Figure 4. Rotor Scan Completion display>

#	Button	Description
1	Rotor Scan Progress Popup	The popup is displayed when Rotor Scan is in progress.
2	Rotor Scan Completion Popup	The popup is displayed when Rotor Scan is completed

When Rotor Scan is completed, the recognized rotor name and number are displayed. The 'OK' button is inactive until the rotor comes to a complete stop.

Once the rotor has completely stopped, the 'OK' button becomes active, Touching the 'OK' button closes the popup.

If the 'OK' button is not touched, the popup automatically disappears after 5 seconds.

If a rotor is not recognized or if a rotor not supported by the centrifuge is detected, a 'Rotor ID Error' popup appears, and the Start button is disabled.

4.4. Setting Speed

When you touch the Speed button on the main screen, a screen for setting RPM/RCF is displayed.

	<ul style="list-style-type: none"> • When setting the speed in RCF, touch the 'RPM/RCF' button.
---	--

[Setting]

- 1) Change the setting speed using the numeric keypad.
- 2) Touch the 'Enter' button to complete the setting.

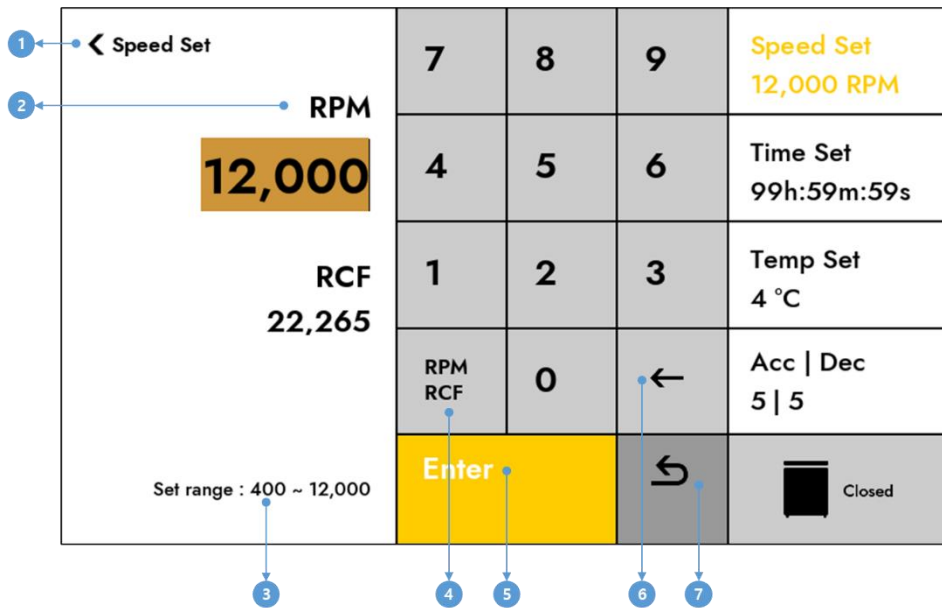

<Figure 5. Speed Set Display>

#	Button	Description
1	Back	Return to the previous screen when touched.
2	Set Value	Display the set value. (Touch the numbers on the keypad to change.)
3	Settings Range	Display the range for setting the speed.
4	RPM/RCF Convert	Convert the speed setting to RPM or RCF.
5	Enter	Complete the set value change.
6	Delete	Delete the last digit of the entered set value.
7	Undo	Cancel the setting change and revert to the previous set value.

4.5. Setting Time

When you touch the Time button on the main screen, a screen for setting the time is displayed.

- Time mode (From Starting Mode/ AT SET SPEED Mode)

To effectively manage time with accuracy, it supports From Starting mode (Time increases from the start) and AT SET SPEED time mode (Time begins counting after reaching the set speed.).

- ▶ From Starting Mode : From t0 to t2
- ▶ AT SET SPEED Mode : From t1 to t2

[Setting]

- 1) Use the numeric keypad to change the setting time.
(Touch the hour, minute, or second area to change the wanted time.)
- 2) Change the Time Count Mode.
(Setting the time to 0 enables continuous run.)
- 3) Touch the "Enter" button to complete the setting.

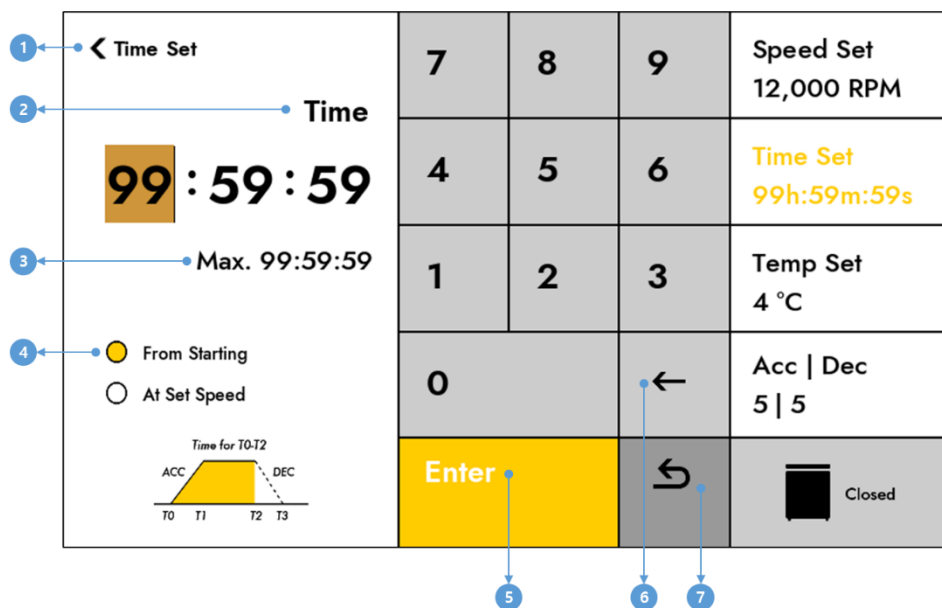

<Figure 6. Time Set Display>

#	Button	Description
1	Back	Return to the previous screen when touched.
2	Set Value	Display the set value. (Touching the numbers on the keypad changes the value.)
3	Maximum Time	Display the maximum permitted time for settings.
4	Time Counting Mode	Set the Time Counting Mode. (Choose between "From Starting" and "At Set Speed".)
5	Enter	Complete the set value change.
6	Delete	Delete the last digit of the entered set value.
7	Undo	Cancel the setting change and revert to the previous set value.

4.6. Setting Temperature

When touch the Temp button on the main screen, a screen for setting the temperature is displayed.

[Setting]

1) Use the numeric keypad to change the setting temperature.

(Touch the "-" button initially to change negative settings. After entering a number, touching the "-" button changes from positive to negative, or from negative to positive.)

2) Touch the "Enter" button to complete the setting.

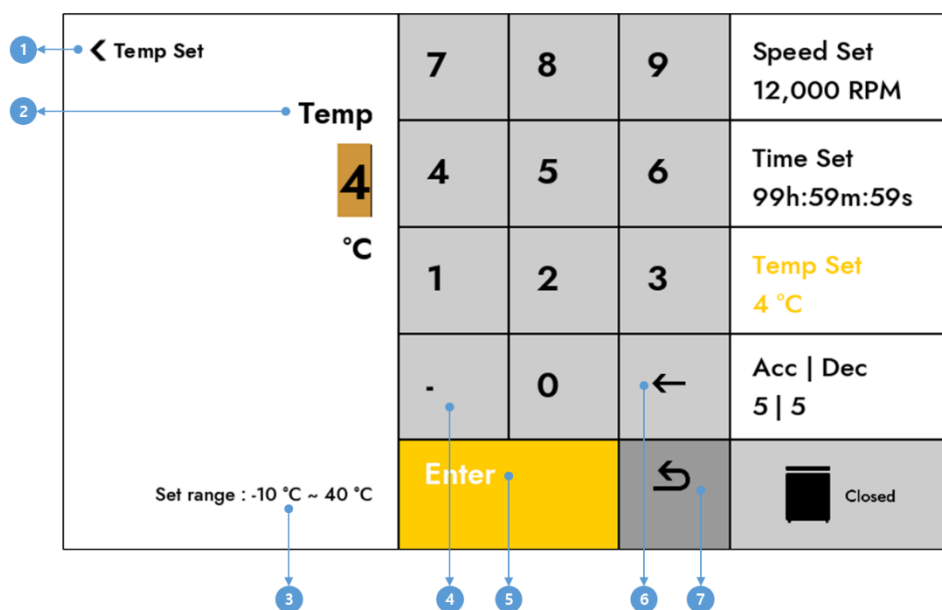

<Figure 7. Temp Set Display>

#	Button	Description
1	Back	Return to the previous screen when touched.
2	Set Value	Display the set value. (Touching the numbers on the keypad changes the value.)
3	Settings Range	Display the range for setting the temperature.
4	-	A button for setting negative values. (After entering a number, converts negative to positive and positive to negative.)
5	Enter	Complete the set value change.
6	Delete	Delete the last digit of the entered set value.
7	Undo	Cancel the setting change and revert to the previous set value.

4.7. Setting Acceleration / Deceleration

When you touch the Acc | Dec button on the main screen, a screen for setting acceleration/deceleration is displayed.

[Setting]

1) Use the numeric keypad to change the setting steps.

(When acceleration change is completed, it transitions to deceleration change state. You can touch the acceleration/deceleration area to change the step.)

2) Touch the "Enter" button to complete the setting.

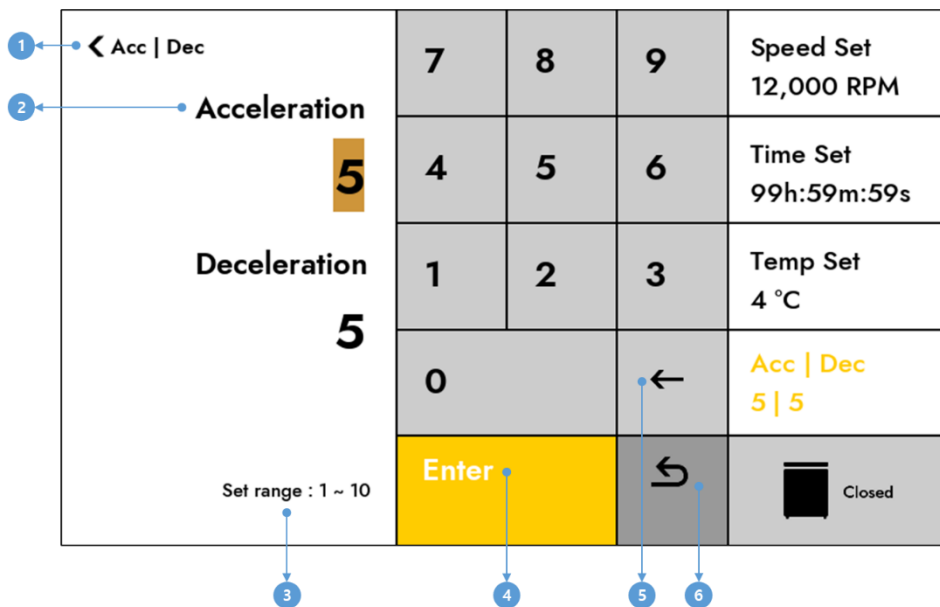

<Figure 8. Acc | Dec Ramp Setting Display>

#	Button	Description
1	Back	Return to the previous screen when touched.
2	Settings Value	Display the set value. (Touching the numbers on the keypad changes the value.)
3	Settings Range	Display the range for setting the Acceleration/Deceleration.
4	Enter	Complete the set value change.
5	Delete	Delete the last digit of the entered set value.
6	Undo	Cancel the setting change and revert to the previous set value.

4.8. Start/Stop

[Start]

1. After finishing inputting the settings, press the Start button. (If the lid is not completely closed, pressing the Start button do not operate. When the operation starts, the Start button changes to the Stop button.)

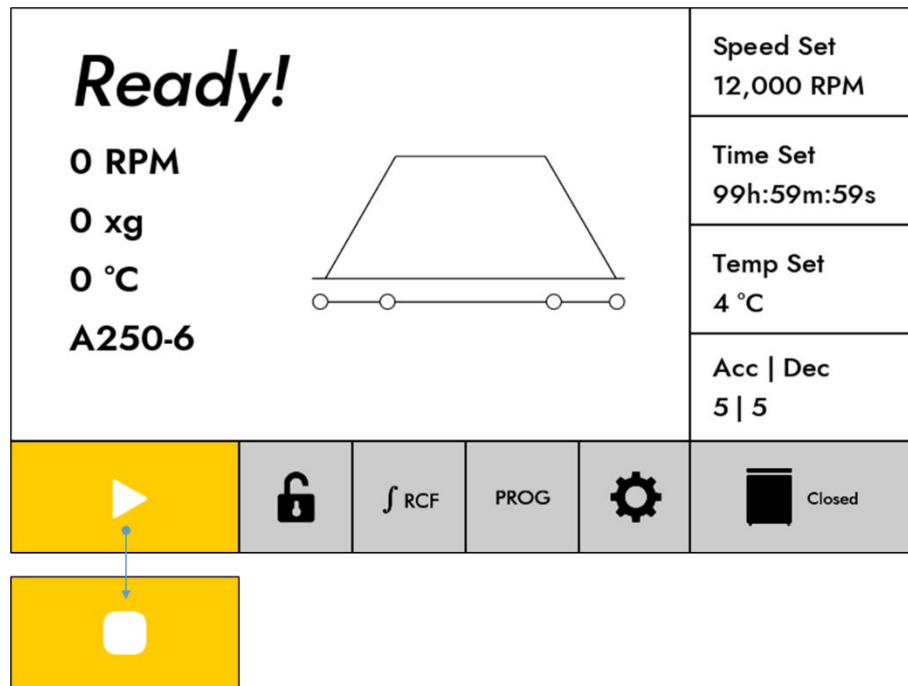

<Figure 9. Changing the start button while in operation >

[Stop]

- 1) If you want to stop while running, please press the Stop button.
(When the operation is complete, the Stop button changes back to the Start button.)

[Stop button while stopping]

When you press the Stop button again while stopping, it decelerates to the maximum deceleration step.

4.9. Pulse (Short spin)

If you press and hold the Start key, the operation starts, and it immediately decelerates when you release the button. (Short spin function)

When the Pulse is in operation, the following icon is displayed:

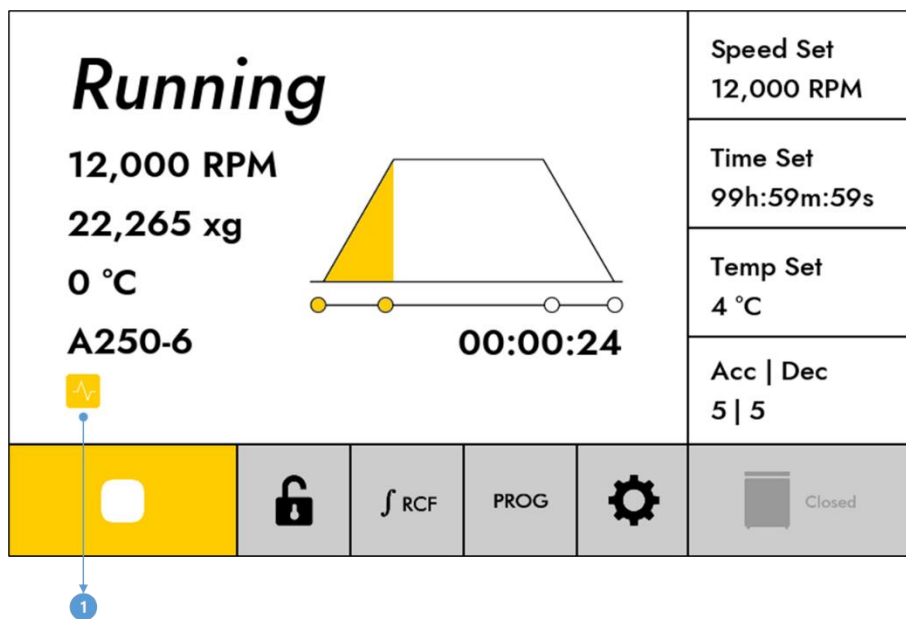

<Figure 10. Pulse Operating Display>

#	Button	Description
1	Pulse icon	The icon that appears during Pulse operation.

4.10. Fastcool

Support the Fastcool function, which allows reaching temperatures at or below room temperature within a short period of time for temperature-sensitive samples.

To activate Fastcool, close the lid and press and hold the Temp Set menu.

- ▶ It reaches the set temperature while rotating at 1,000 RPM.
- ▶ The time increases during Fastcool operation.
- ▶ If you want to end the process when the set temperature is reached, press the Stop key.

When Fastcool is in operation, the following icon is displayed:

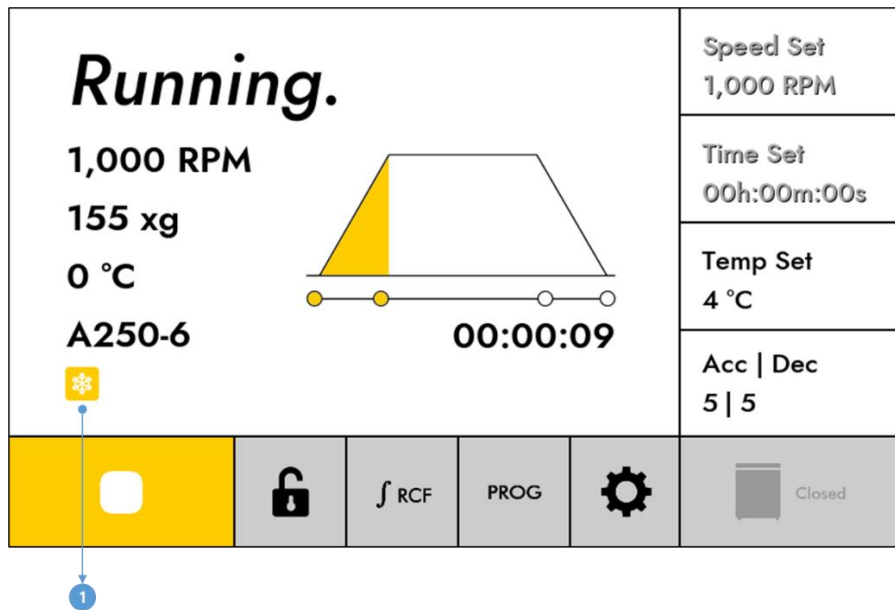

<Figure 11. Fastcool Operating Display >

#	Button	Description
1	Fastcool icon	The icon that appears during Fastcool operation.

During Fastcool operation, speed / time settings are not available. (Menu button is inactive.)

4.11. Changing set value while in operation

It supports the ability to change speed / time / Acc / Dec settings during operation.

1. When you want to change the set values during operation,

press the mode button that matches and adjust the RPM / time / Acc / Dec settings.

- ▶ After completing the setting changes, press the [ENTER] button to apply the changed values to the operation.
- ▶ During Fastcool / Multi-Step operation, settings can't be changed, and all setting buttons is locked.

4.12. Setting Lock/Unlock

When Key Lock is activated, all buttons except the [LOCK] button is in a locked state.

When locked, the lock button icon changes and the screen remains locked until the lock button is touched again.

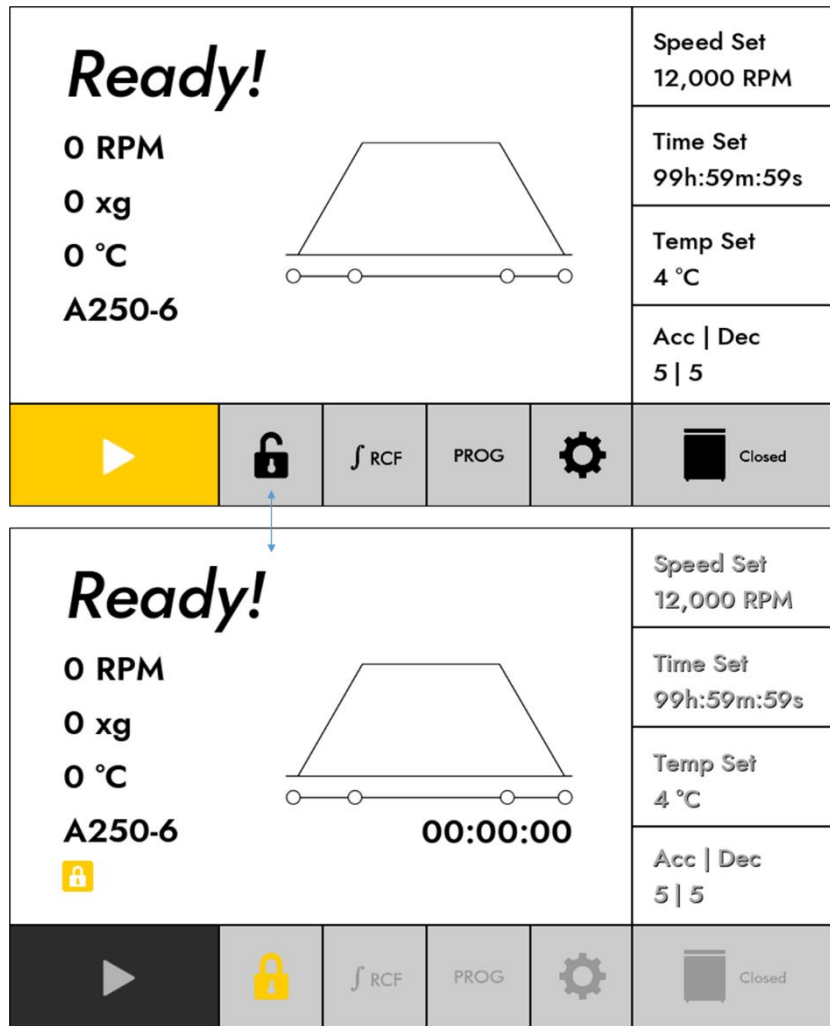

<Figure 12. Lock/Unlock Display>

4.13. Indicating Cumulative RCF

While touching the "∫RCF" button, the accumulated RCF value is displayed on the screen.

(The accumulated RCF value is displayed in the area showing the current RCF value, and it is only displayed while the button is being pressed.)

4.14. Program Setting

When you touch the Program button, a screen for saving / deleting / calling programs is displayed.

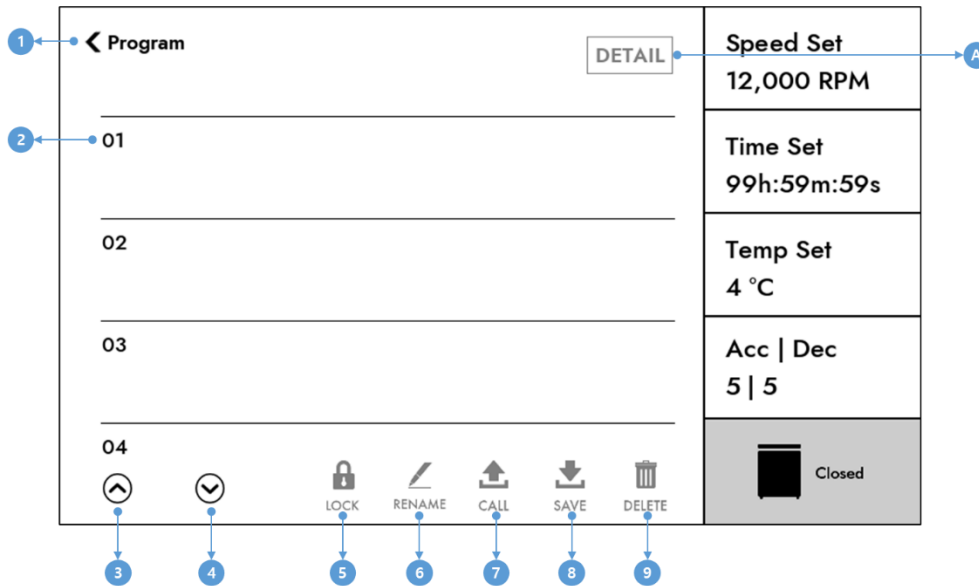

<Figure 13. Program Display>

#	Button	Description
1	Back	Return to the previous screen when touched.
2	Program List	Display the stored Program List.
3	Up	Scroll Up the Program List. (Press and hold for fast scrolling.)
4	Down	Scroll Down the Program List. (Press and hold for fast scrolling.)
5	LOCK	Change the selected Program to a locked state. (Prompt for password entry screen upon button click.)
6	RENAME	Change the name of the selected Program. (Prompt for name input screen upon click.)
7	CALL	Call the selected Program.
8	SAVE	Save settings to the selected Program Index number.
9	DELETE	Delete the selected Program.
A	DETAIL	Display details of the selected Program. (Disabled when clicking on an unsaved Program Index.)

4.14.1. Program Saving

To save the current settings to the preferred Program order.

- 1) Enter the wanted speed, temperature, time, acceleration, deceleration, or other settings to be saved.
- 2) Enter the Program screen.
- 3) Touch the number (1~100) you want to save and select the "SAVE" button. Next, specify a name for the Program to save it.

4.14.2. Program Delete

To delete a stored Program.

[Delete]

- 1) Select the Program you want to delete.
(If an unsaved list is selected, the "DELETE" button is inactive.)
- 2) Touch the "DELETE" button.
- 3) When the deletion confirmation message appears, touch the "OK" button to delete the Program.

4.14.3. Program Calling

To apply the current settings to a stored Program.

[Calling]

- 1) Select the Program you want to call.
(If an unsaved list is selected, the "CALL" button will is inactive.)
- 2) Touch the "CALL" button.
- 3) When the call confirmation message appears, touch the "OK" button to call the Program.

4.14.4. Program Rename

To rename a stored program.

[Rename]

- 1) Select the Program you want to rename.
(If an unsaved list is selected, the "RENAME" button is inactive.)
- 2) Touch the "RENAME" button.
- 3) When the screen for editing the name is displayed, enter the preferred name, then touch the "Enter" button to complete the name change.

4.14.5. Program Lock

To prevent deletion of stored programs by locking them with a password.

[Setting]

- 1) Select the program you want to lock.
(If an unsaved list is selected, the "LOCK" button is inactive.)
- 2) Touch the "LOCK" button.
- 3) When the password setup screen is displayed, enter the preferred password (4-8 digits), and touch the "Enter" button to finish setting the lock.

4.14.6. Program Unlock

To unlock a program that has been locked.

[Unlocking]

1) Select the program you want to unlock.

(If you select an unsaved list, the "LOCK" button is inactive. If you select a locked list, the "UNLOCK" button is displayed.)

2) Touch the "UNLOCK" button.

3) When the password setting screen appears, enter the password you set when locking the program or the Admin password, then touch the "Enter" button to complete the unlocking process.

(The Admin password can be changed via the Settings -> General -> Change Admin Password menu, and the default value is "0000.")

4.15. Setting

Confirming and Changing Centrifuge Functions.

4.15.1. Multi-Step

A function that allows you to operate the centrifuge while changing the speed and time up to 5 times during centrifugation.

[Setting]

1) Touch the "+" button to set the speed, time, and acceleration/deceleration for "Step 1".

(When adding a new step, set the speed, time, and acceleration/deceleration in that order.)

2) Set the speed, time, and acceleration/deceleration for "Step 2" to "Step 5".

(Up to 5 steps can be added, and operation is possible with one or more steps added.)

3) Click the "START" button at the bottom to start the operation.

(The "START" button is displayed at the bottom of the screen when one or more steps are added.)

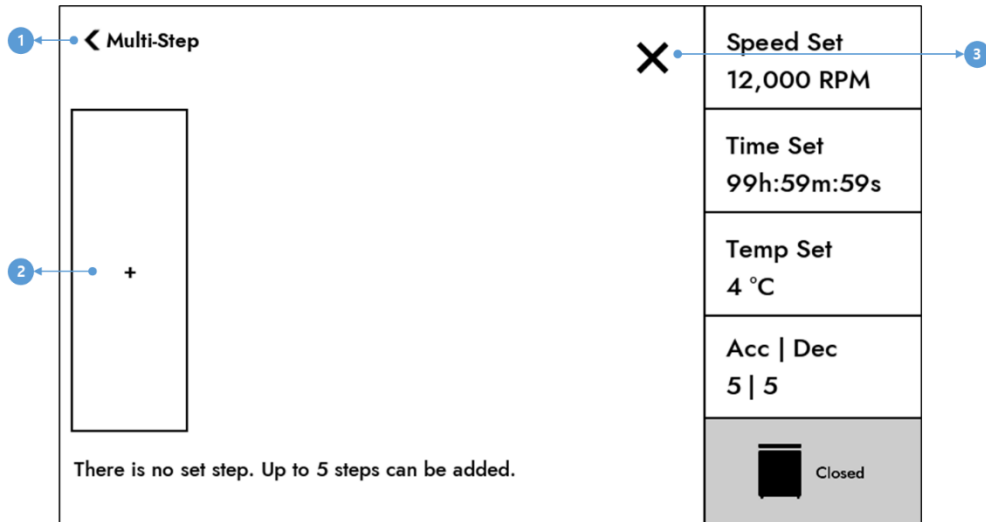

<Figure 14. Multi-Step Display>

#	Button	Description
1	Back	Return to the previous screen when touched.
2	+	Display a screen for setting up a new step.
3	Close	Return to the main screen.

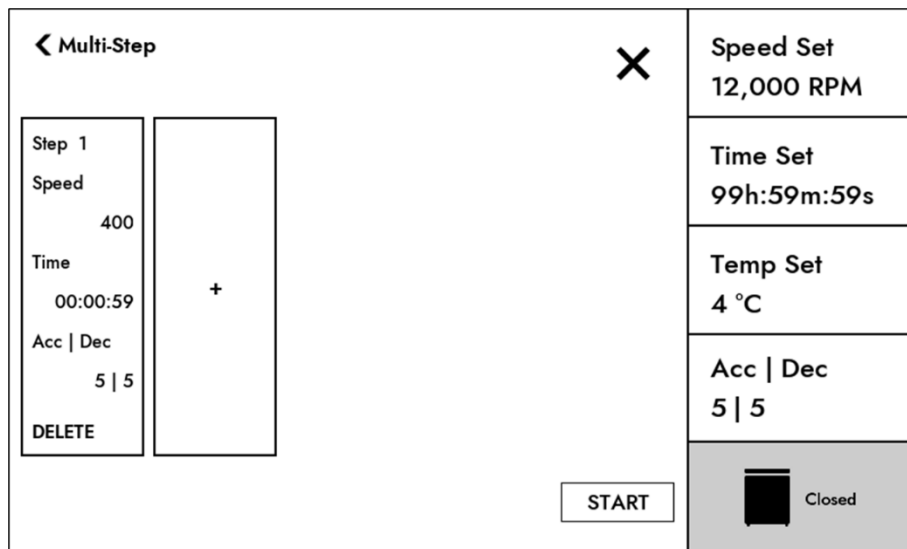

<Figure 15. Step 1 Setting Display>

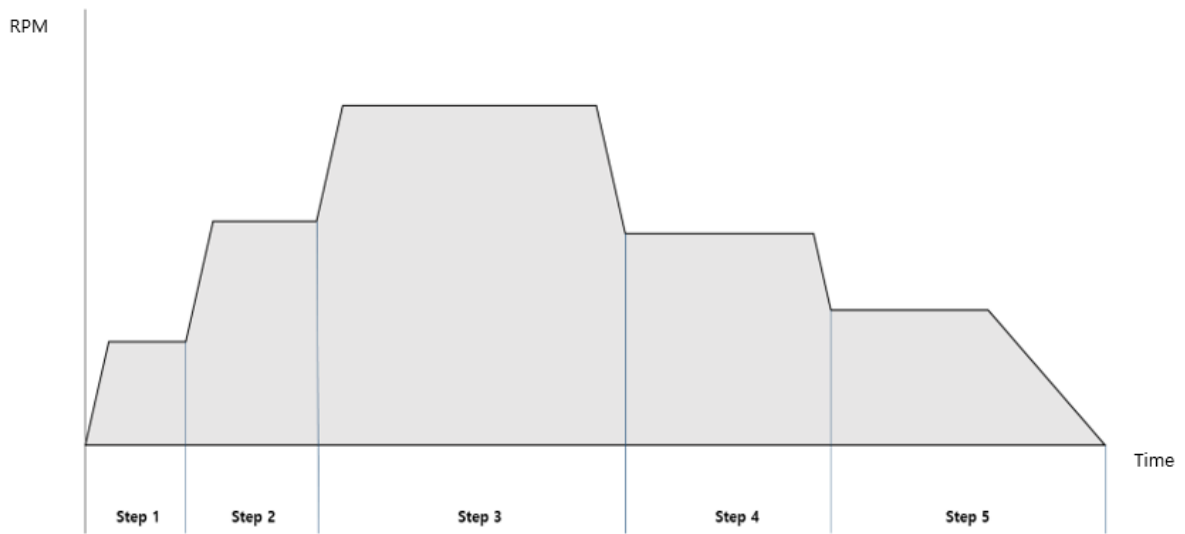

<Figure 16. Step 5 Setting Operation Diagram>

4.15.1.1. Setting Speed



- Multi-Step speed can only be set in RPM, and each step must be set with at least a 100 RPM difference compared to the previous step.

When the speed setting screen is displayed, use the keypad to set the preferred speed.

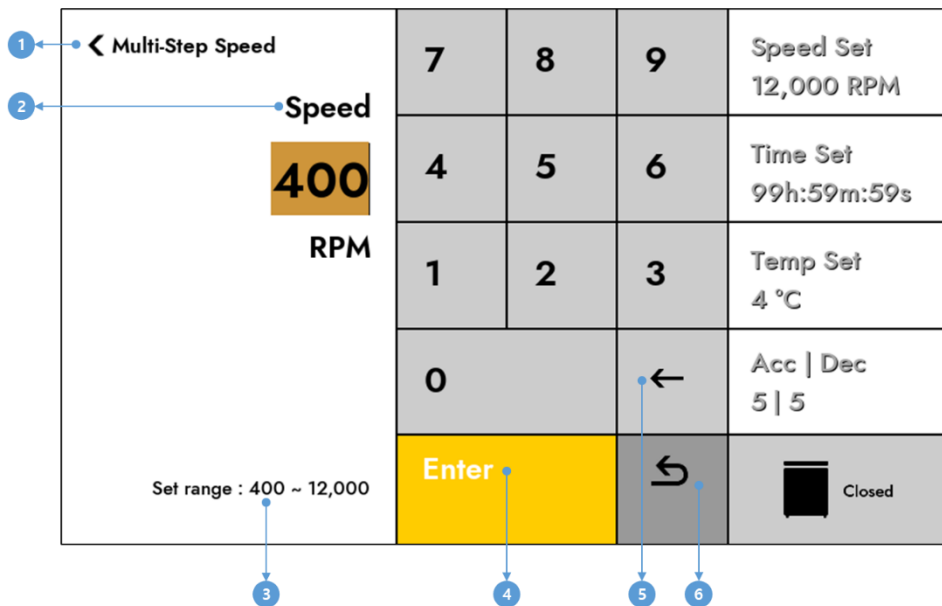

<Figure 17. Multi-Step Speed Setting Display>

#	Button	Description
1	Back	Return to the previous screen when touched.
2	Set Value	Display the set value. (Touching the numbers on the keypad changes the value.)
3	Settings Range	Display the range for setting the Speed.
4	Enter	Complete the set value change.
5	Delete	Delete the last digit of the entered set value.
6	Undo	Cancel the setting change and revert to the previous set value.

4.15.1.2. Setting Time

After completing the speed setting, the time setting screen is displayed.

Set the time for centrifugation at the selected speed. The multi-step time cannot be set to "00:00:00".

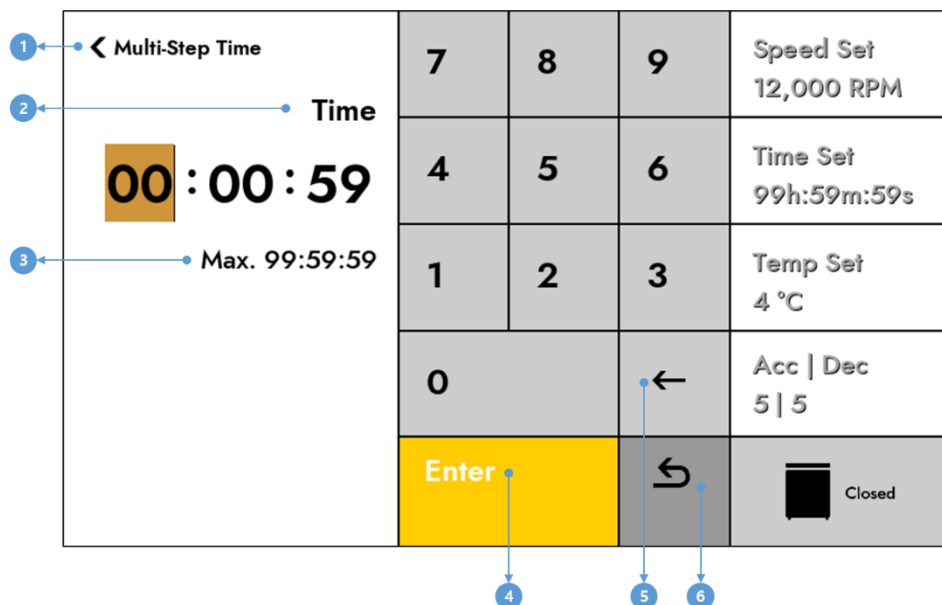

<Figure 18. Multi-Step Time Setting Display>

#	Button	Description
1	Back	Return to the previous screen when touched.
2	Set Value	Display the set value. (Touching the numbers on the keypad changes the value.)
3	Maximum Time	Display the maximum permitted time for settings.
4	Enter	Complete the set value change.
5	Delete	Delete the last digit of the entered set value.
6	Undo	Cancel the setting change and revert to the previous set value.

4.15.1.3. Setting Acceleration/Deceleration

When the time setting is completed, the acceleration/deceleration setting screen is displayed.

Setting the acceleration/deceleration ramp level for the current step.

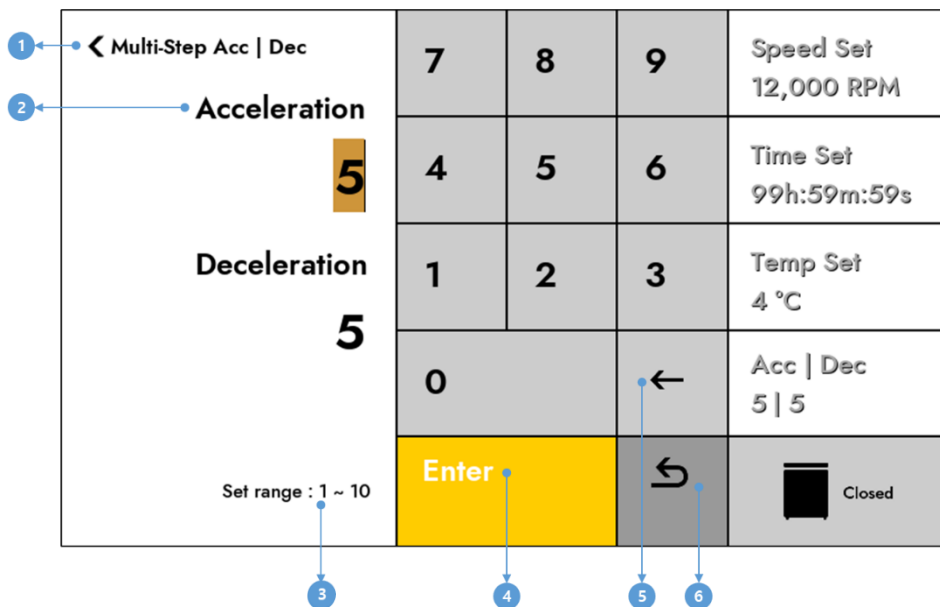

<Figure 19. Multi-Step Acc | Dec Setting Display>

#	Button	Description
1	Back	Return to the previous screen when touched.
2	Set Value	Display the set value. (Touching the numbers on the keypad changes the value)
3	Settings Range	Display the range for set acceleration/deceleration.
4	Enter	Complete the set value change.
5	Delete	Delete the last digit of the entered set value.
6	Undo	Cancel the setting change and revert to the previous set value.

4.15.2. History



- All history is stored up to a maximum of 5,000 entries, and if it exceeds 5,000, the oldest entries is deleted.

You can review the centrifuge operating history, event history, and error history.

4.15.2.1. Operating History

You can review the centrifuge operation history and save it to a USB.

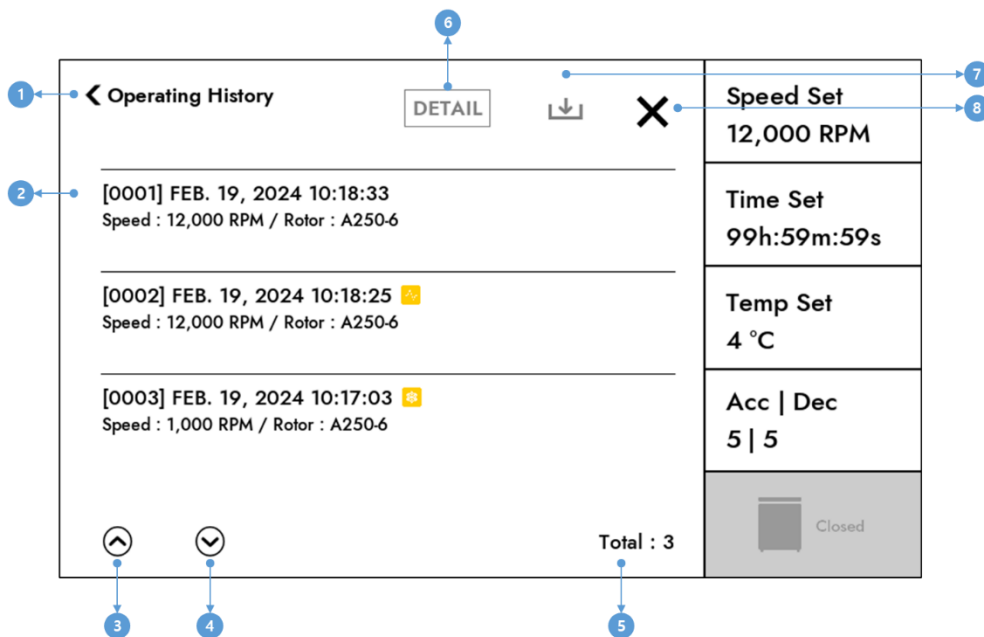

< Figure 20. Operating History Display >

#	Button	Description
1	Back	Return to the previous screen when touched.
2	History List	Display the centrifuge operation history. (An icon is displayed next to the Fastcool and Pulse operation history on the right.)
3	Up	Scrolling up the History List. (Long-pressing allows for fast scrolling.)
4	Down	Scrolling down the History List. (Long-pressing allows for fast scrolling.)
5	Total	Display the number of stored histories.
6	DETAIL	Review the complete set values of the selected item in the History List. (If the History List is not selected, it is inactive.)
7	Export	Saving centrifuge history to USB. (Inactive if USB is not connected.)
8	Close	Return to the main screen.



- If centrifuge operation history has been saved to the USB at least once, a popup appears asking whether to save history after the previously saved date.

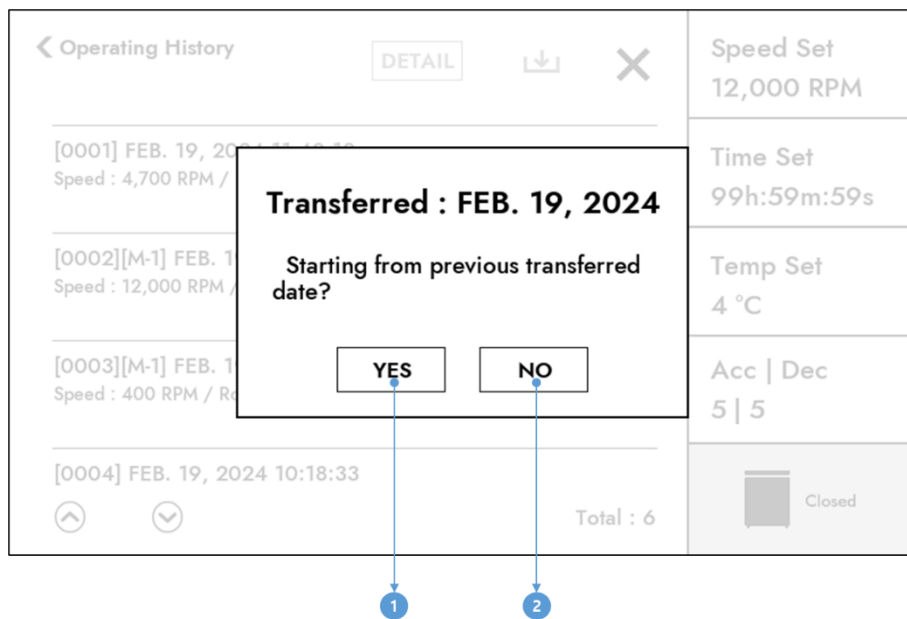

<Figure 21. Saving Confirmation Display>

#	Button	Description
1	YES	Save operation history from the previously saved date.
2	NO	Save all operation history.

4.15.2.2. Event History

You can review the history of centrifuge operations and save it to a USB.

The items included in the event history are as follows.

#	Item
1	When settings are changed (Speed, Speed type, Time, Time count mode, Temp, Acc Dec)
2	When the status of the lid changes (Open, Closed)
3	When the rotor ID is changed
4	When the operation status changes (Operation Start / Operation Done)
5	When an error occurs
6	When the program status changes (Add, Delete, Name Change, Calling)
7	When data is exported
8	When Multi-Step settings change
9	When S-Curve settings change

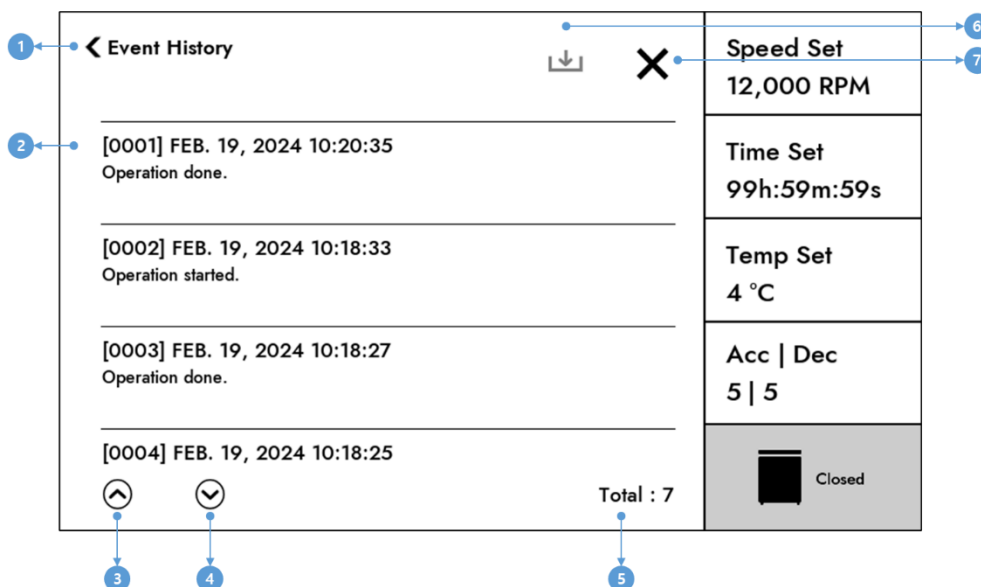

<Figure 22. Event History Display>

#	Button	Description
1	Back	Return to the previous screen when touched.
2	Event History List	Display the device handling history.
3	Up	Scrolling up the History List. (Long-pressing allows for fast scrolling.)
4	Down	Scrolling down the History List. (Long-pressing allows for fast scrolling.)
5	Total	Display the number of stored histories.
6	Export	Saving device handling history to USB. (Inactive if USB is not connected.)
7	Close	Return to the main screen.



- If centrifuge operation history has been saved to the USB at least once, a popup appears asking whether to save history after the previously saved date.

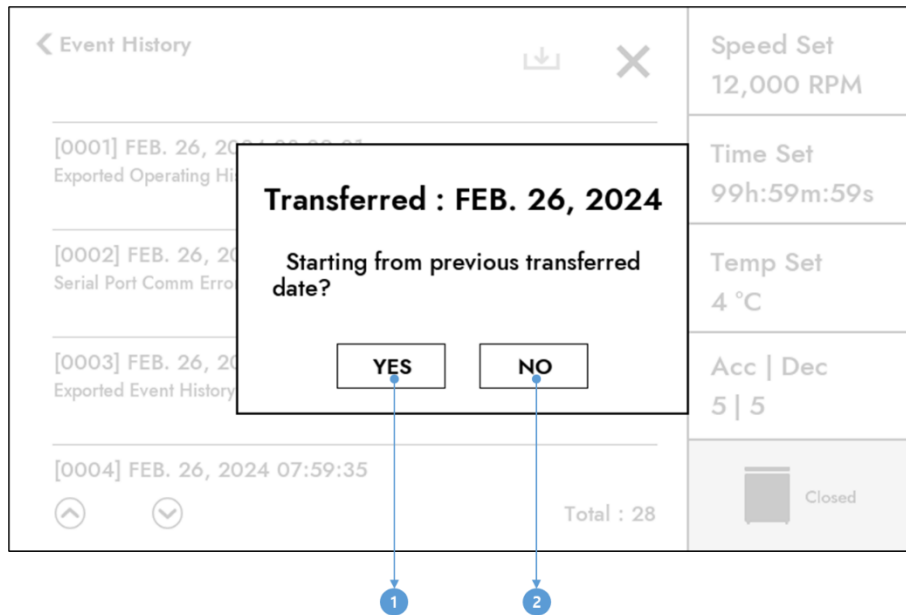

<Figure 23. Saving Confirmation Display >

#	Button	Description
1	YES	Save operation history from the previously saved date.
2	NO	Save all operation history.

4.15.2.3. Error History

You can review the centrifuge error occurrence history and save it to a USB.

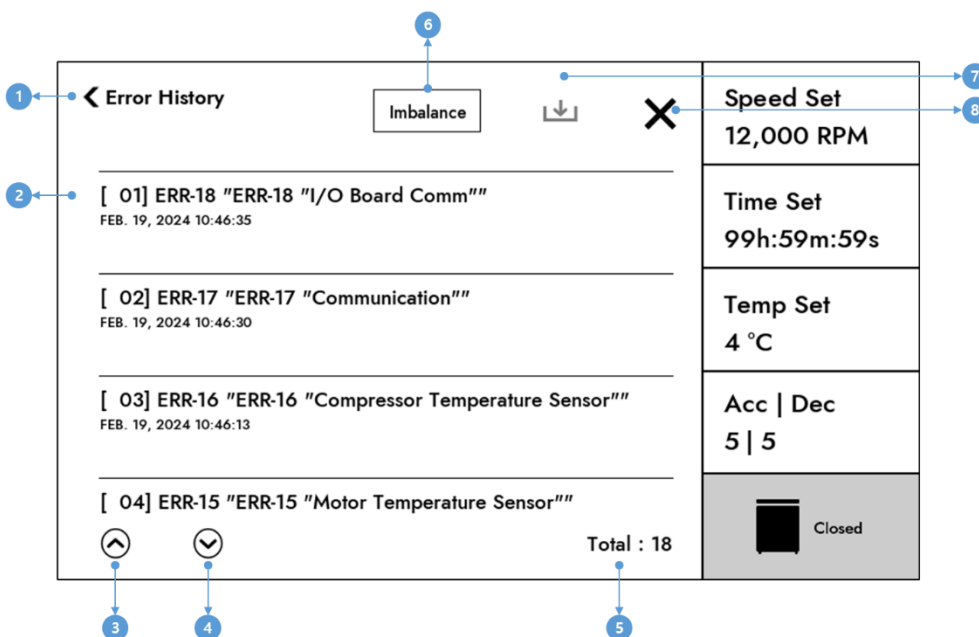

<Figure 24. Error History Display>

#	Button	Description
1	Back	Return to the previous screen when touched.
2	Error History List	Display error history.
3	Up	Scrolling up the History List. (Long-pressing allows for fast scrolling.)
4	Down	Scrolling down the History List. (Long-pressing allows for fast scrolling.)
5	Total	Display the number of stored error histories.
6	Imbalance	A button to specifically check Imbalance history.
7	Export	Saving error history to USB. (Inactive if USB is not connected.)
8	Close	Return to the main screen.

4.15.3. RPM/RCF Converter

It's a function that calculates RPM \leftrightarrow RCF based on the entered radius.

When the RPM input value is changed, the RCF value is automatically calculated and displayed.

When the RCF input value is changed, the RPM value is automatically calculated and displayed.

When the radius input value is changed, the RCF value is automatically calculated and displayed.

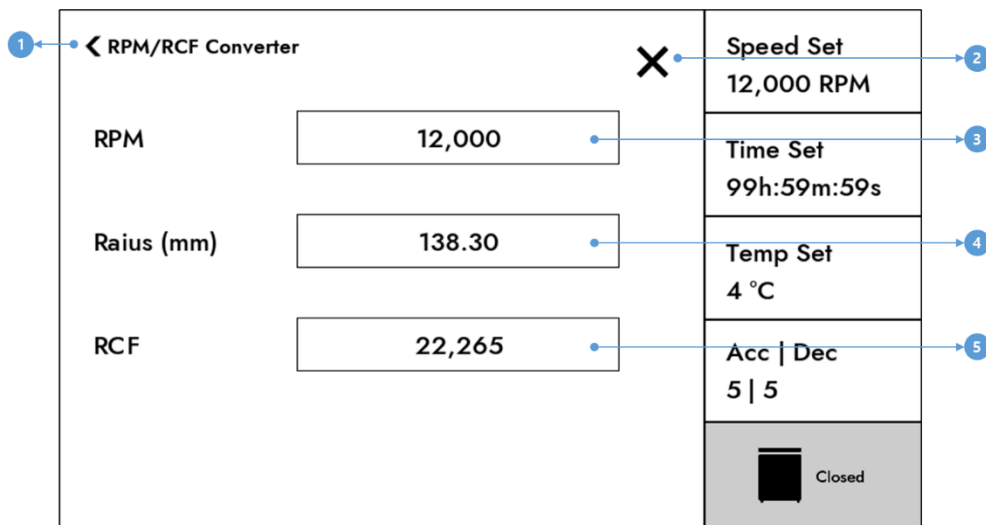

<Figure 25. RPM/RCF Converter Display>

#	Button	Description
1	Back	Return to the previous screen when touched.
2	Close	Return to the main screen.
3	RPM	Display the RPM setting screen, when touched.
4	Radius	Display the Radius setting screen, when touched.
5	RCF	Display the RCF setting screen, when touched.

4.15.4. General

You can change various settings of the device.

4.15.4.1. Sounds

You can adjust the sound of the device.

[Sounds Setting]

- 1) Change the Switch button of the Sound Enable option to "ON" state. (Only if it's currently "OFF".)
- 2) Touch the "-" and "+" buttons of the Sound Volume option to adjust the volume.
(If the switch button for the Sound Enable option is "OFF", the Sound Volume option isn't displayed.)
- 3) Once volume adjustment is completed, exit the settings screen.

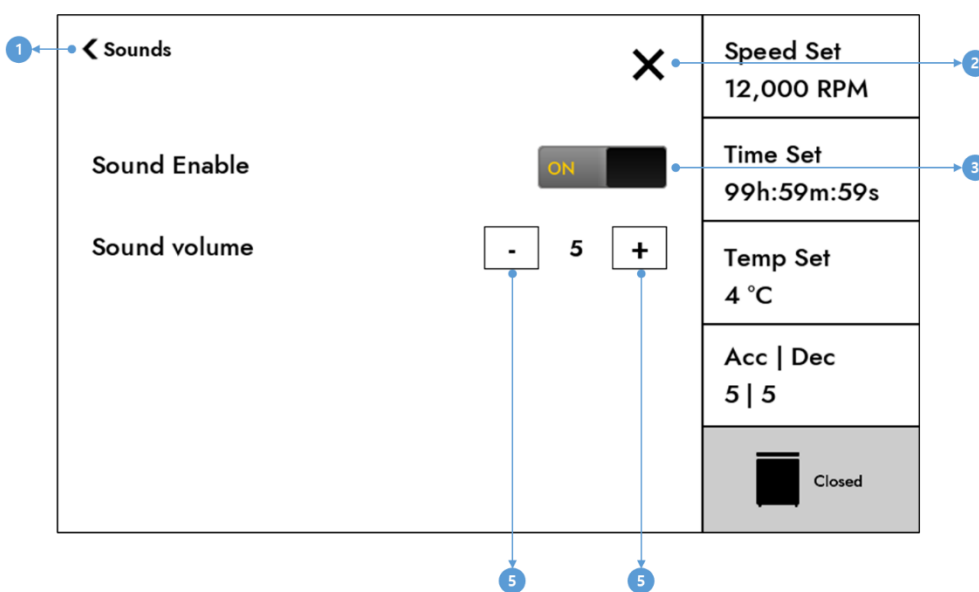

<Figure 26. Sound Setting Display>

#	Button	Description
1	Back	Return to the previous screen when touched.
2	Sound Enable	Change the Sound Enable setting using the Switch button.
3	"-"	Lower the volume.
4	"+"	Turn up the volume.
5	Close	Return to the main screen.

4.15.4.2. Lamp Control

You can turn the lamp off and on.

[Lamp Enable ON]

You can check the device status based on the lamp color. (Refer to the "4.1. Lamp" for lamp colors.)

[Lamp Enable OFF]

The lamp turns off.

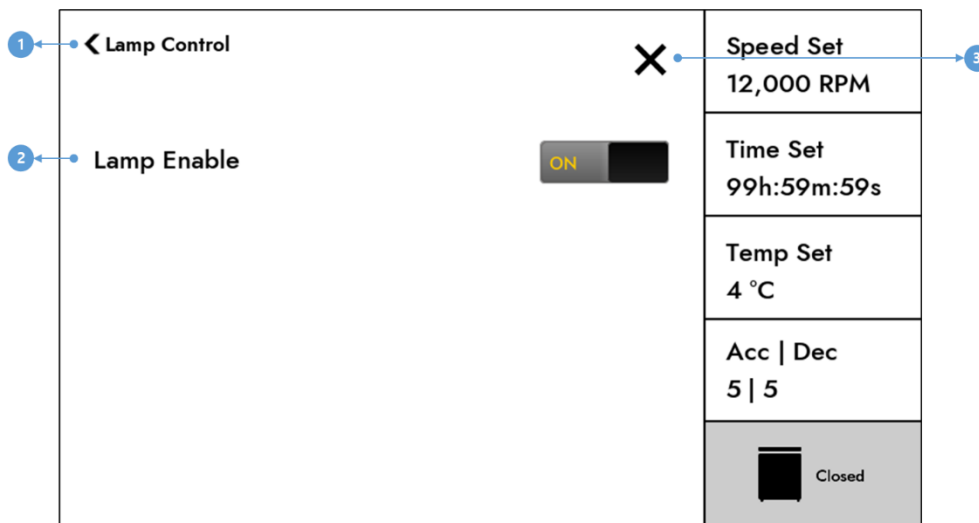

< Figure 27. Lamp Control Display >

#	Button	Description
1	Back	Return to the previous screen when touched.
2	Lamp Enable	Change the Lamp Enable setting using the Switch button.
3	Close	Return to the main screen.

4.15.4.3. Date and Time

You can set the date and time of the device.

[Time Setting]

- 1) Set the continent and city in the TimeZone area. (Touch to display the list popup.)
- 2) Click the "Apply TimeZone" button to set the TimeZone. (Touching will display a reboot notification popup, and clicking "OK" will reboot the device, applying the set time to the device.)

- 3) Re-enter the Date and Time menu.
- 4) Change the date using the Up/Down buttons.
- 5) Change the time using the Up/Down buttons.
- 6) Click the "Apply Time" button to apply the time. (When touched, a reboot notification popup is displayed, and clicking "OK" will reboot the device, applying the set time to the device.)

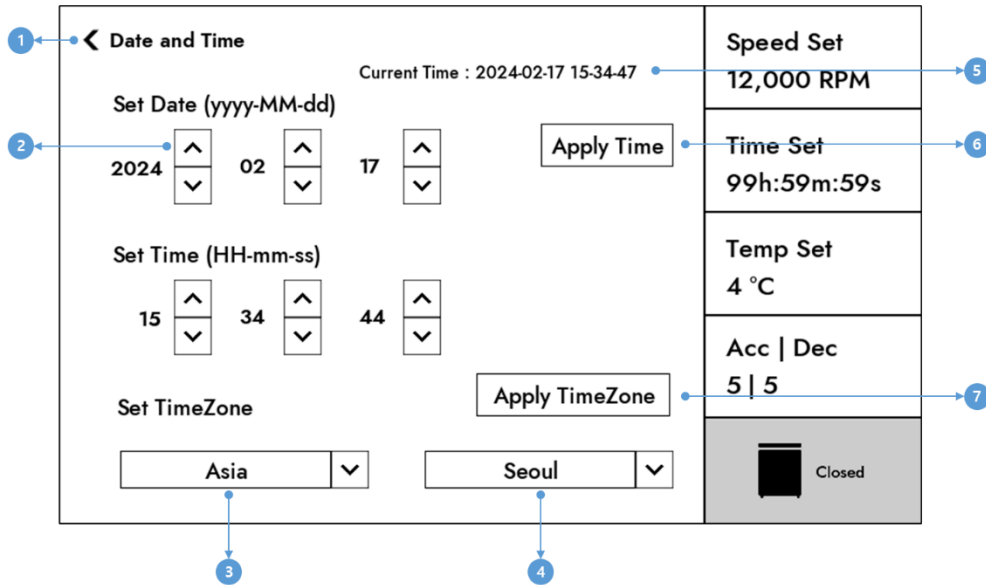

< Figure 28. Date and Time Setting Display >

#	Button	Description
1	Back	Return to the previous screen when touched.
2	UP/ Down	Change the Date and Time values.
3	Region Setting	Display the region. When touched, the list of regional settings is displayed.
4	Location Setting	Display the location. When touched, the location setting list is displayed.
5	Current Time Display	Display the current time.
6	Apply Time	Set the arranged date and time.
7	Apply TimeZone	Set the TimeZone.

4.15.4.4. Change Admin Password

Change the Admin password. (The Admin password is used for unlocking, deleting programs, etc.)

- 1) Enter the current password using the keypad and then click the Enter button.
- 2) Enter the new password using the keypad and then click the Enter button.
(It must be a 4-digit number.)
- 3) Re-enter the password you entered in item 2) using the keypad, then click the Enter button.

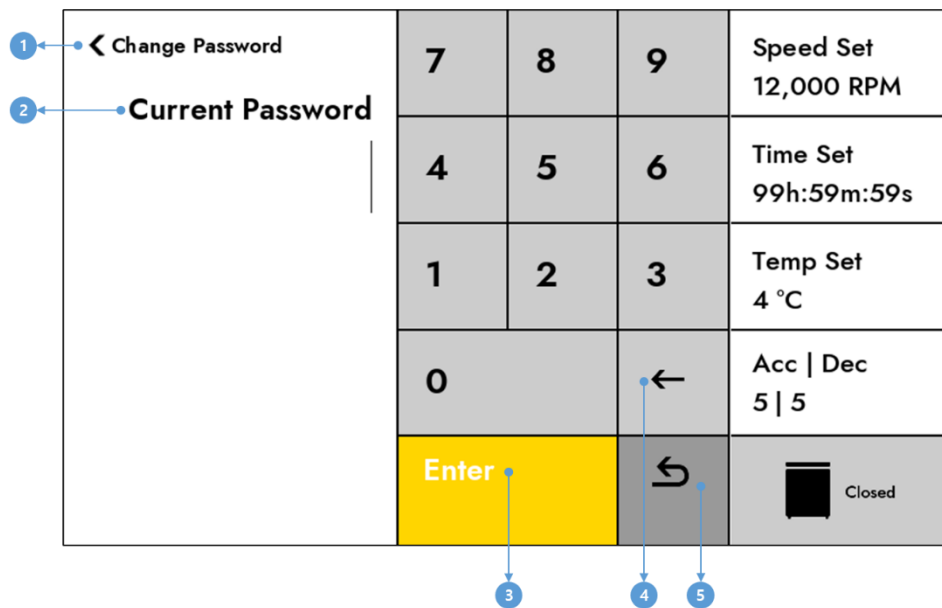

< Figure 29. Change Admin Password Setting Display >

#	Button	Description
1	Back	Return to the previous screen when touched.
2	Password Display Area	Display the entered password.
3	Enter	Complete the password input.
4	Delete	Delete the last digit of the entered password.
5	Undo	Cancel the password change and delete the entire entered password.

4.15.4.5. Total Run Time

Display the operating time of the device.

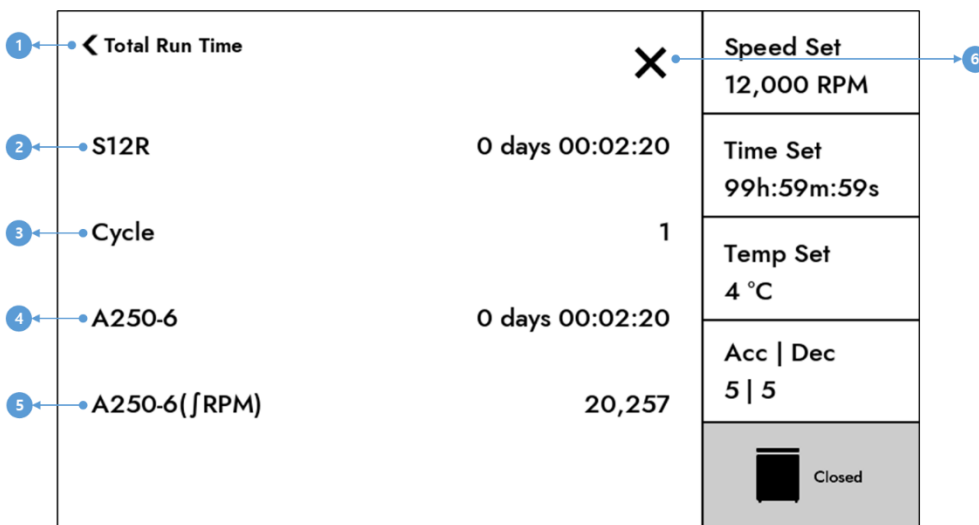

<Figure 30. Total Run Time Display>

#	Button	Description
1	Back	Return to the previous screen when touched.
2	Total Run time	Display the total centrifugation time of the device.
3	Device cycle	Display the total number of centrifugation cycles of the device. (The cycle is included only when the configured RPM is reached.)
4	Rotor operating time	Display the total centrifugation time of the rotor.
5	Rotor cumulative RPM	Display the cumulative RPM of the rotor.
6	Close	Return to the main screen.

4.15.4.6. Device Info.

Display the information about the device.

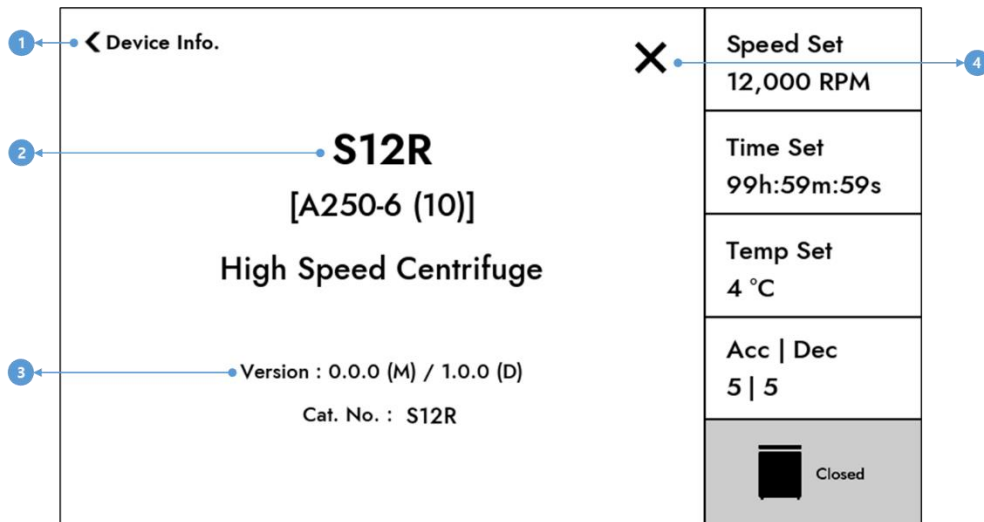

< Figure 31. Device Info Display >

#	Button	Description
1	Back	Return to the previous screen when touched.
2	Device name	Display the device name and the installed rotor name and ID.
3	Version	Display the program version.
4	Close	Return to the main screen.

4.16. Error Message Display

If an error occurs while the device is in operation or standby, a pop-up with an error number and error phrase and a sound will occur.

If an error is not resolved even when you close the pop-up with the "OK" key, the number of errors will be displayed in the upper left corner of the screen.

Clicking the number of errors will display the pop-up again, showing the error number and error message.

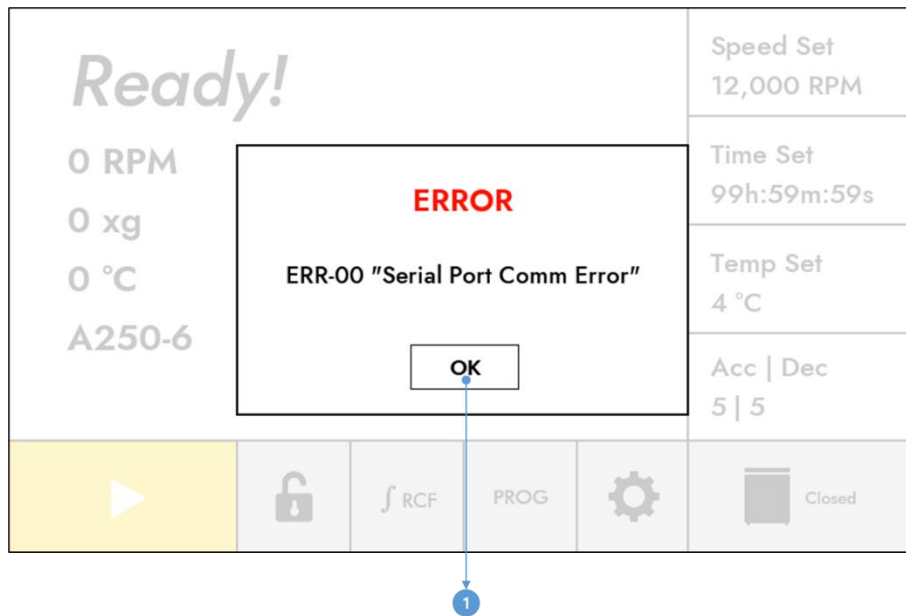

< Figure 32. Error occurrence Display >

#	Button	Description
1	OK	Close the popup.

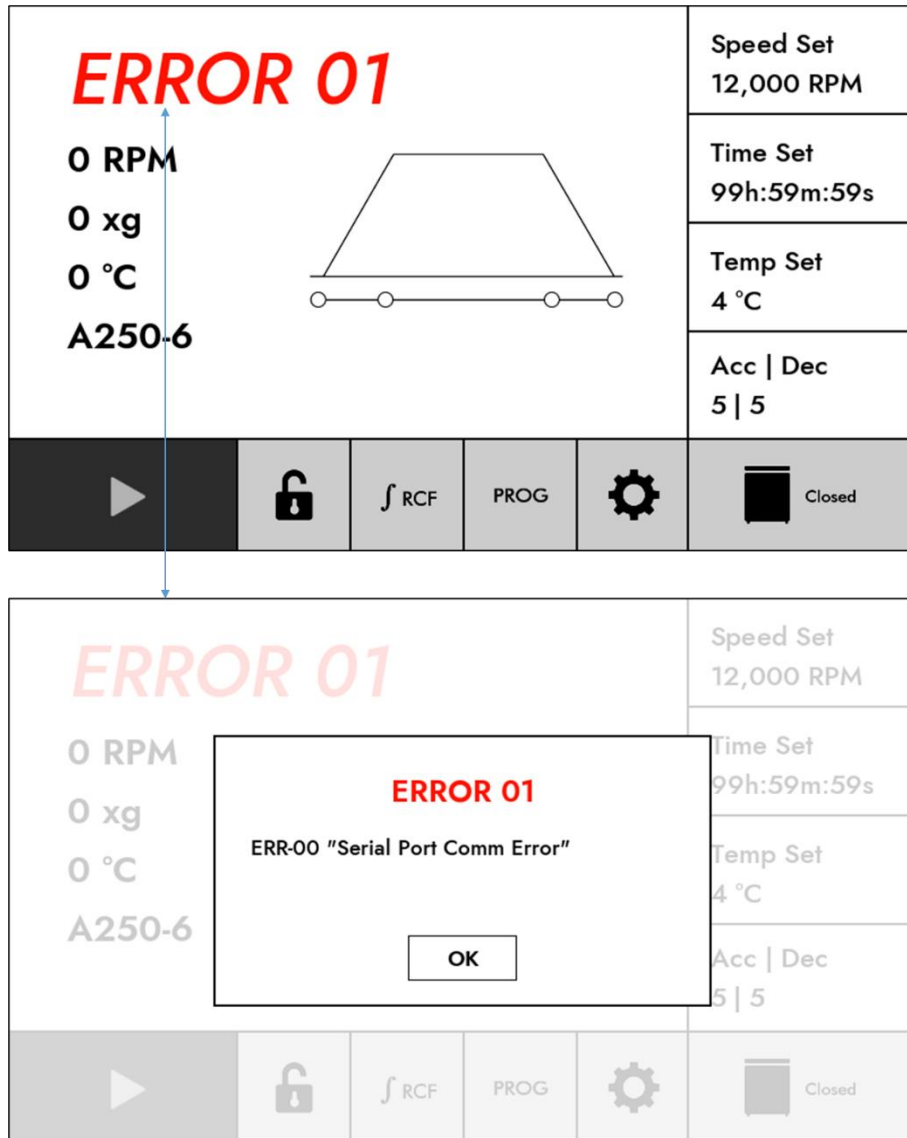

Even if you press the "OK" button to close the pop-up after an error occurs, the number of errors that have occurred will be displayed as shown in the screen below, and you can touch the number of errors that have occurred to check the errors that have occurred.



<Figure 33. Error Confirmation Display>

5. Maintenance



5.1. User Checklist

	Warning!
	<p>Risk of damage due to a defective lid shock absorber.</p> <ul style="list-style-type: none"> • We recommend that you check the lid shock absorber every two years. • Open the lid completely and make sure it is secured. • If you have any problems with the lid shock absorber, contact the service team of Hanil Scientific Inc.
	<p>Risk of product damage due to insufficient or belated maintenance.</p> <ul style="list-style-type: none"> • Follow the maintenance cycles and procedures recommended by the manufacturer. • Select the disinfection method under applicable laboratory and legal regulations. • When performing maintenance, check that the device and parts are not damaged or defective. • Perform regular inspections of electrical safety, a device, parts, etc. at least every 12 months at an official service center of Hanil Scientific Inc. • Contact us for information on main body parts and consumables. • Dust accumulation in the vent may cause device failure or fire.

1. Check that the connection point of the rotor hub is not separated or bent.
2. Rotate the shaft manually and check if there is any noise or if it rotates smoothly.
3. Visually inspect the rotor for any cracks, clean the connection points, and check for any signs of wear.
4. Set the time to 10 minutes and use a stopwatch to verify the accuracy of the time.
5. Prepare four pieces of paper of the same size (2cm wide x 15cm long) and place them evenly spaced on the rubber packing of the chamber upper part with the lid open.
Close the lid. If the lid is completely sealed, the paper won't slide smoothly when pulled due to friction.
6. Recommend that centrifuges installed one year ago have regular maintenance checks at least once a year.
7. Recommended to have the surface condition and balance of rotors of more than 5 years checked.
8. Recommended to inspect rubber consumables such as motor anti-vibration rubber and rotor O-ring every 2-3 years.

9. The shock absorber is composed of a gas spring, so it is recommended to inspect every 2 years.
10. This device does not use a user-replaceable fuse.
11. Check the ventilation holes regularly to prevent dust accumulation.
12. Check the accessories for damage before use and replace any damaged accessories.

5.2. Check the level

	Caution!
	Risk of shaft damage due to non-horizontal. <ul style="list-style-type: none">• If the product is not in a level position, it may cause imbalance or damage to the motor shaft.

1. Always use a level to check the balance after installing or moving the device.
2. Place a Bubble Leveler on the rotor lid handle after inserting the rotor to balance it.

5.3. Care Instructions for Refrigerated device

For the S12R, being a refrigerated device, please check of the following:

5.3.1. Open the lid after centrifugation

1. Wipe up the moisture in the chamber with a soft cloth.
2. Leave the centrifuge lid open after centrifugation.

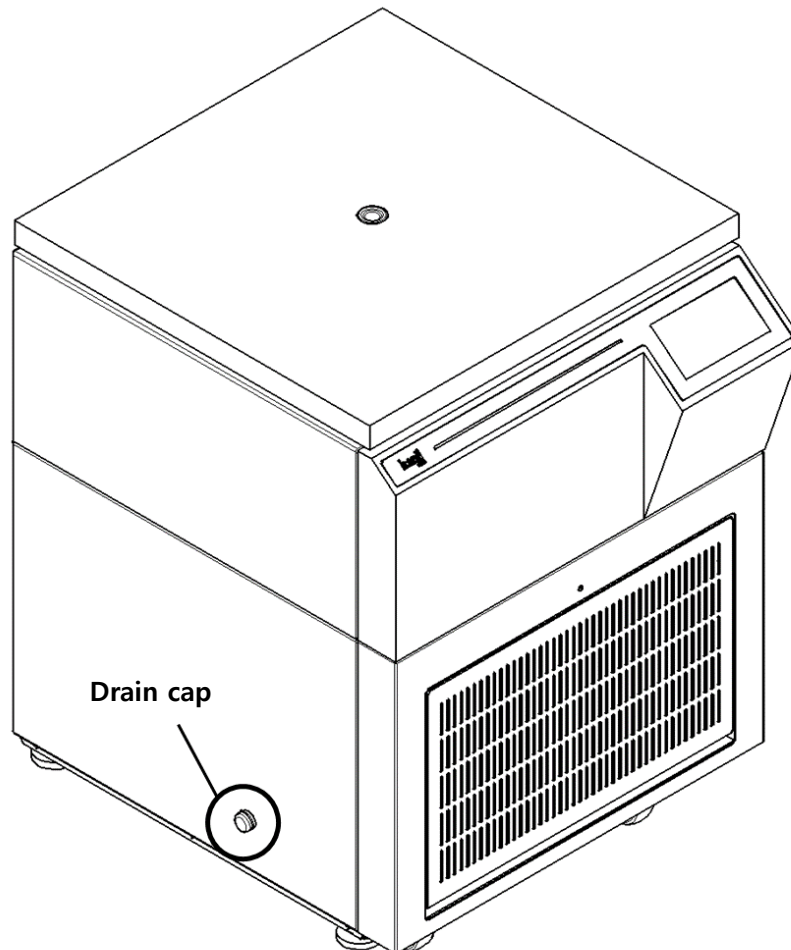

5.3.2. Remove the condensation water

1. On the left side of the device, there is a "Drain Cap" to remove condensation water.
2. Remove the drain cap and empty the condensation water regularly.



	Note!
	Close the drain cap <ul style="list-style-type: none">• Please close the drain cap after fully tightening before using the device.• Operating with the drain cap is not fully closed, cooling air is discharged to the outside through the drain hose, which reduces cooling efficiency.







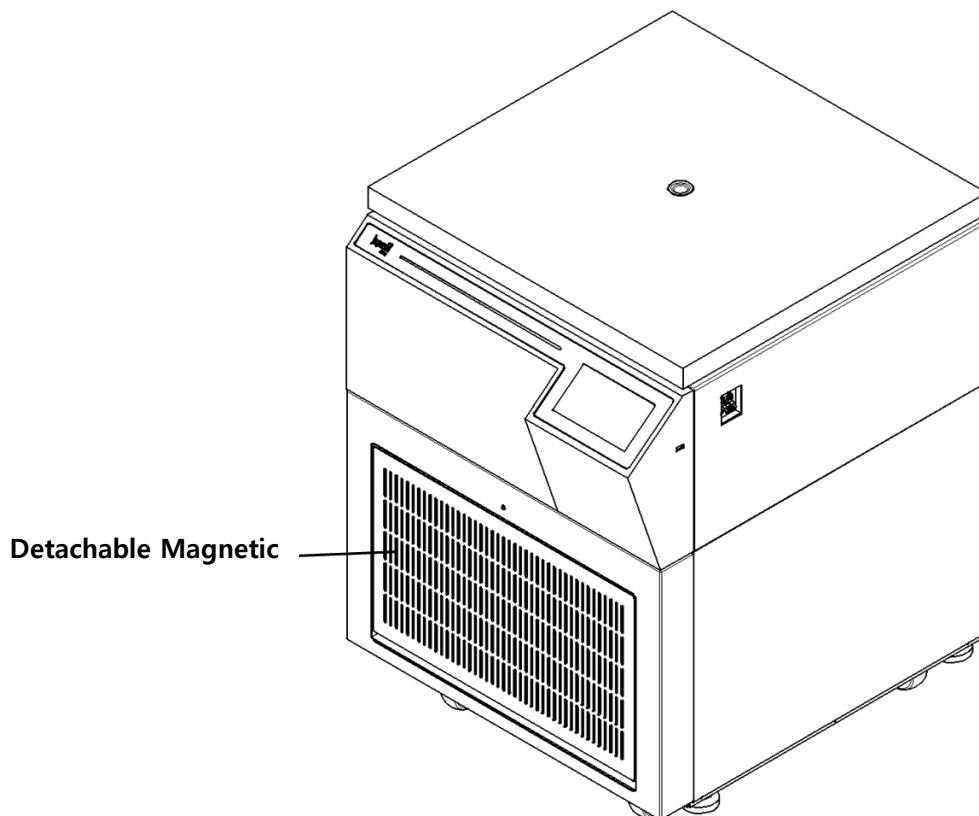

5.3.3. Remove dust







	<p>Warning!</p>
	<p>Risk of crushing when opening and closing the ventilation.</p> <ul style="list-style-type: none"> • When opening and closing the ventilation, be careful of your fingers. • After closing the ventilation, you must double-check the closed state.
	<ul style="list-style-type: none"> • Dust accumulation in the vent may cause device failure or fire.

1. On the front of the device, there is a ventilation slots installed in the area where the compressor is built-in.
2. Regularly check the ventilation slots and remove any dust to prevent malfunction.



5.4. Cleaning and decontamination

	<p>Danger!</p>
 	<p>Risk of electric shock if the power is not disconnected.</p> <ul style="list-style-type: none"> • Before cleaning the device, ensure it has completely stopped, then turn off all power sources, and unplug the product from the electrical outlet.
	<p>Risk of electric shock due to skipped drying.</p> <ul style="list-style-type: none"> • After cleaning, washing, and removing any contamination, ensure all parts of the device are completely dry before connecting the power source.
 	<p>Before washing, guidance.</p> <ul style="list-style-type: none"> • The product should be placed on a flat surface before cleaning or washing. • When moving the device to another location, clean and disinfect both the exterior and interior before relocation. • Put on appropriate personal protective equipment before cleaning or decontaminating. • When performing tasks such as cleaning, disinfecting, or decontamination, follow the safety regulations of your institution.
	<p>Before return the device, guidance.</p> <ul style="list-style-type: none"> • When returning products or parts for service, repair, or disposal, disinfect or remove any contaminants. • Be sure to fill out a "Decontamination Confirmation Form" and send it together with the device. The "Decontamination Confirmation Form" can be downloaded from the Documents section of the SUPPORT tab on the www.ihanil.com website.
	<p>Risk of product damage due to liquid permeation.</p> <ul style="list-style-type: none"> • Be careful to prevent liquids from entering the device, as this can damage electrical, electronic, and mechanical components. • Do not place containers filled with liquids on top of or near the product.
	<p>Risk of component damage due to exceeding sterilization tolerances.</p> <ul style="list-style-type: none"> • When sterilizing by high-pressure steam, do not exceed the specified temperature and time limits (121°C, 20 minutes). Exceeding the tolerances may result in component deformation or device malfunction.

	Warning!
	<p>Risk of damage to products and parts due to mechanical or chemical damage.</p> <ul style="list-style-type: none"> • Do not use damaged, cracked, or corroded products or parts. • Do not use corrosive chemicals such as strong bases, weak bases, strong acids, cesium, silver, mercury, other heavy metals, phenol, formaldehyde, etc. • If the device or accessories are contaminated, turn off the power immediately and clean it. • Organic solvents may cause damage to the rotor. • After using organic solvents, immediately clean the accessories and the device used.
	Caution!
	<p>Do not use metal-based cleaning tools.</p> <ul style="list-style-type: none"> • Do not use the metal scrubbing or wire brush. This will peel off the product coating and cause corrosion.
	Note!
	<p>Do not store bleach</p> <ul style="list-style-type: none"> • Use freshly made 10% bleach for disinfection each time. • Bleach loses its effectiveness after 24 hours when diluted with water, so use it immediately without storing it.

5.4.1. Cleaning

In the event of a spill or contamination, promptly clean all internal and external parts of the centrifuge, including the chamber, motor shaft, and rotor, using a suitable decontamination agent.

Check the chemical resistance before applying any decontamination agent.

[Unit]

1. If the device is contaminated due to sample leakage, clean it with a soft cloth soaked in neutral detergent. Then, dry completely with a dry soft cloth.
2. Do not use chemicals such as alcohol, benzene, toluene, etc., as they can damage the device.
3. Be careful not to create scratches on the surface of the device during movement or cleaning.

Do not use cleaning tools with rough surfaces that can cause damage.

4. In case of rust due to prolonged dampness after use, clean the rust with a neutral detergent and dry it with a cloth.

[Chamber]

1. Keep dry inside the chamber after every use.
2. In case of chamber contamination, immediately dampen a soft sponge with lukewarm water and neutral detergent, clean the area, and then wipe it dry with a soft cloth.

[Motor shaft]

1. An imbalance issue may occur due to contaminants staining the shaft. Always maintain the motor shaft clean.
2. After using the instrument, take out the rotor from the shaft, and wipe the shaft with dry soft cloth to keep it dry.
3. If the rotor cannot be removed from the shaft, do not remove the rotor with excessive force. Contact a service center.

[Rotor]

1. If liquid spills from the tube and gets on the rotor, immediately wipe it with a soft cloth dampened with warm water. Be careful not to damage the specially treated surface of the rotor during cleaning.
2. Wipe the tube holes of the fixed angle rotor with a soft non-ferrous test tube cleaning brush, and dry with an absorbent cloth or paper.
3. Check the tube holes of the fixed angle rotor for contamination of the solution and keep it dry. Fixed angle rotors during a long time of non-use, separate the rotor lid and store the main body upside down.
4. After cleaning the rubber ring on the lid fastening part of the fixed angle rotor, lightly apply lubricant before use.

5.4.2. disinfection

1. Disinfect using 10% bleach (1 part undiluted bleach, 9 parts water).
2. Weekly disinfect the exterior of the centrifuge.
3. disinfect the interior of the centrifuge (chamber, lid inner, motor cover, shaft, rotor, buckets, adapters, and tube rack) at least once a month.

5.4.3. Decontamination of hazardous materials





1. Radioactive materials

- ▶ Radioisotope contamination can be removed by first cleaning with 50% ethanol, followed by cleaning with 10% SDS. Gloves or all materials used to clean radioactive materials should be collected together and disposed of properly according to laboratory regulations.

2. Biologically hazardous materials

- ▶ If the dirt or spill is in a sealed container (rotor or bucket), only the sealed container should go through the decontamination process.
- ▶ check that no damaged areas and small holes have occurred in the rotor or bucket that could allow hazardous materials to escape.

5.5. Emergency Lid Open

	Note!
	Manual lid open <ul style="list-style-type: none"> When the lid cannot be opened automatically and the device is not powered, samples can be removed from the rotor using this method.
	Warning!
	Disconnect the power after stopping operation. <ul style="list-style-type: none"> Before opening the lid in an emergency, be sure to turn off all power and unplug the cable from the outlet after the device has stopped working.
	Risk of injury and sample damage when opening the lid manually. <ul style="list-style-type: none"> Manual lid opening must be performed after the machine has completely stopped rotating. Failure to follow this may result in damage to the sample or the user. Do not close the lid immediately after the emergency opening. Wait for the power to be restored before using the device normally. Only use the manual lid open in an emergency.

1. Turn off the main power switch. Check whether the rotor has come to a complete stop.
2. Check the Manual Lid Open hole on the right side of the device.
3. Insert the Manual Lid Open Tool (T-wrench) provided with the device into the Manual Lid Open Hole and turn it clockwise.

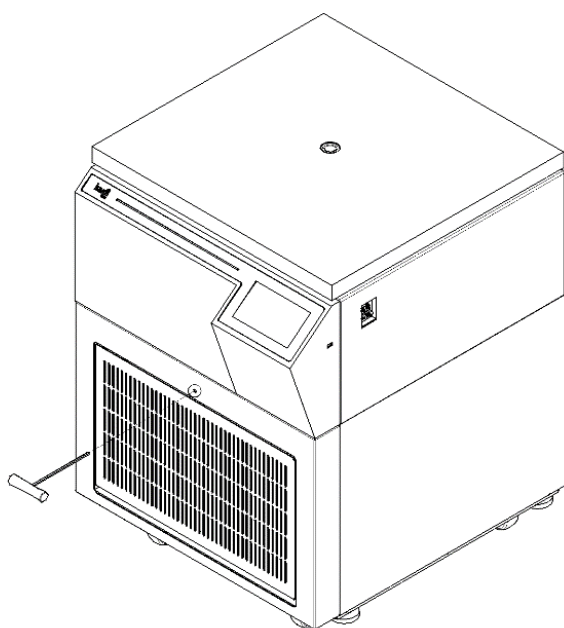

5.6. Disposal



This device is marked with a wheeled bin symbol with a cross, indicating that it should not be disposed of with unsorted municipal waste.

Protecting the environment and preventing pollution spread require proper disposal of both the equipment and waste.

This product cannot be disposed of as household waste and always dispose of it in accordance with local waste disposal regulations and guidelines.

If necessary, please contact the supplier for assistance.

6. Troubleshooting

6.1. Possible Problems

Before contacting the service center for any problems with the centrifuge, please check the following:

Symptom	Check List
Power failure.	Please refer to [3.3. Power Connection] to check if the power plug is disconnected.
Can't be operated	If the lid does not close, it will not operate. Please refer to [3.4. Opening/Closing the Lid] to check the lid status and ensure it is closed properly.
Noise and vibration during running	If the installation location of the main unit is unstable, please check the horizontal alignment and stability of the main unit. Reinstall it on a flat surface, ensuring it is level.
	If the rotor attachment state is not good, after removing the rotor, check the outside of the rotor, and if there are any damaged areas, immediately stop using the rotor. Also, if the attachment method is incorrect, please refer to [3.5. Installing/Removing the Rotor] to correctly attach the rotor.
	If the tube insertion is asymmetric or the weights do not match, please refer to [3.6. Loading Tubes] to verify the tube weights and insert them symmetrically.
Imbalance error	When there is an issue with the imbalance sensor inside the device, the "Imbalance Error!" message during initial startup. If this error occurs, pressing the start button will not activate the device. In such cases, please contact Hanil Science Inc. service center.





6.2. Error codes

Error	Message	Cause	Recommended Action
E00	Serial Port Comm Error	This error is displayed, when communication between the Display and Main Board is interrupted.	Please reboot the device. If the error persists, contact Hanil Science Inc. service center.
E01	Motor Start Error	The error is displayed, when the motor fails to reach 50 RPM within 10 seconds after pressing the Start button.	Please reboot the device. If the error persists, contact Hanil Science Inc. service center.
E02	Lid Open Error	The error is displayed when the lid is opened during operation.	Please reboot the device. If the error persists, contact Hanil Science Inc. service center.
E03	Motor Over Heating	The error is displayed when the motor overheats.	Please reboot the device. If the error persists, contact Hanil Science Inc. service center.
E06	Over Speed	The error is displayed when the measured speed exceeds the set speed.	Please reboot the device. If the error persists, contact Hanil Science Inc. service center.
E08	Imbalance Error	The error is displayed when the rotor is not horizontal.	Please check if the samples inside the tube are symmetrically inserted with the same amount/density. Please check if the device is in a horizontal position. If the error continues, contact Hanil Science Inc. service center.
E09	RPM Sensor Error	The error is displayed when there is a problem with the RPM sensor.	Please reboot the device. If the error persists, contact Hanil Science Inc. service center.
E10	Rotor ID Error	The error is displayed when there is a failure in rotor recognition or an unsupported rotor is attached.	If the error continues after attaching the supported rotor, please contact Hanil Science Inc. service center.

Error	Message	Cause	Recommended Action
E12	Chamber Bottom Sensor	The error is displayed when there is a problem with the chamber temperature sensor.	Please reboot the device. If the error persists, contact Hanil Science Inc. service center.
E15	Motor Temperature Sensor	The error is displayed when there is a problem with the motor temperature sensor.	Please reboot the device. If the error persists, contact Hanil Science Inc. service center.
E16	Comp Temperature Sensor	The error is displayed when there is a problem with the compressor temperature sensor.	Please reboot the device. If the error persists, contact Hanil Science Inc. service center.
E18	I/O Board Comm	The error is displayed when communication with the I/O board is interrupted.	Please reboot the device. If the error persists, contact Hanil Science Inc. service center.
E20	Lid Error (Door In1)	The error is displayed when there is a problem with the lid (Door In1) sensor.	Please reboot the device. If the error persists, contact Hanil Science Inc. service center.
E21	Lid Error (Door Close)	The error is displayed when there is a problem with the lid (Door Close) sensor.	Please reboot the device. If the error persists, contact Hanil Science Inc. service center.
E22	Lid Error (Door Open)	The error is displayed when there is a problem with the lid (Door Open) sensor.	Please reboot the device. If the error persists, contact Hanil Science Inc. service center.
E23	Lid Error (Door In2)	The error is displayed when there is a problem with the lid (Door In2) sensor.	Please reboot the device. If the error persists, contact Hanil Science Inc. service center.
E28	Imbalance Sensor	The error is displayed when the imbalance sensor is not connected	Please reboot the device. If the error persists, contact Hanil Science Inc. service center.

Error	Message	Cause	Recommended Action
E29	Imbalance Magnet	The error is displayed when there is no magnet to detect imbalance	Please reboot the device. If the error persists, contact Hanil Science Inc. service center.
E40	Model Selection	The error is displayed when an unsupported model is selected.	Please reboot the device. If the error persists, contact Hanil Science Inc. service center.
E43	Inverter Connection Error	The error is displayed when the inverter connection is disconnected.	Please reboot the device. If the error persists, contact Hanil Science Inc. service center.
E47	Compressor Overheating	The error is displayed when the compressor temperature is overheated.	Please reboot the device. If the error persists, contact Hanil Science Inc. service center.

7. Rotor & Accessories

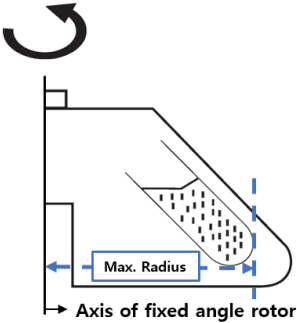
	<p>Caution!</p>
	<p>Precautions when inserting the sample tubes.</p> <ul style="list-style-type: none"> • If the density of the entire sample exceeds 1.2 g/mL, the maximum rotation speed should be reduced to prevent rotor overload and rotor damage.
	<p>Risk of injury and product damage due to the use of unauthorized accessories and spare parts.</p> <ul style="list-style-type: none"> • Use only provided the rotors, parts, and accessories by Hanil Scientific Inc. Hanil Scientific Inc. is not responsible for damages to the device or accidents caused by using parts and accessories not recommended.
	<p>Mean of Max. Radius</p> <p>Max. Radius of each rotor means the distance from the rotor hole or bucket to the inside edge of the adapter bore based on the rotor axis.</p> <div style="text-align: center;">  <p>Max. Radius of Fixed angle rotor</p> </div>

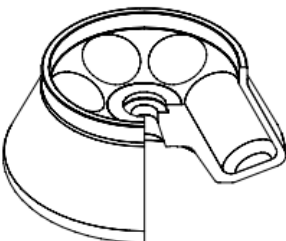
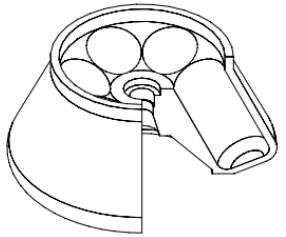
Rotor		Tube Capacity /Bottom Type	Required Adaptor	Bore Ø x L Radius(mm)	Max. RPM (rpm) Max. RCF (xg)
<p>A250-6</p>  <p>Hole angle : $\angle 25^\circ$ Max. Capacity : 6 x 250 mL Size (Ø x H) : $\varnothing 295.6 \times 147.8$ mm Max. height for tube fit : 132 mm Incl. a coupling bolt lid</p>	250mL Flat	-	62 x 103 138.3	12,000 22,265	
	100mL Round	TR100(250)	44.2 x 93 124.5	12,000 20,044	
	85mL Round	TR85(250)	38.5 x 96 122.5	12,000 19,722	
	50mL Conical(Skirt)	TR50sc(250)	29.8 x 93 125	12,000 20,124	
	50mL Conical	TR50c(250)	29.8 x 98 119	12,000 19,158	
	50mL Round	TR50-2(250)	29.5 x 90 120	12,000 19,319	
	30mL Round	TR30-3(250)	26 x 85 132.5	12,000 21,331	
	25mL Conical	TR25c(250)	29.5 x 61.5 120	12,000 19,319	
	15mL Conical	TR15c-4(250)	17.2 x 104.5 131	12,000 21,090	
	15mL Round	TR15-4(250)	17.5 x 103.5 133.5	12,000 21,492	
	10mL Round	TR10-7(250)	16 x 80 133.5	12,000 21,492	
	5mL Round	TR7-8(250)	13.5 x 60 135.5	12,000 21,814	
	5mL Conical	TR5c-4(250)	17.2 x 50 131	12,000 21,090	
	1.5mL/2mL	TR2.0-9(250)	11.1 x 39 135	12,000 21,734	
<p>A500-6</p>  <p>Hole angle : $\angle 25^\circ$ Max. Capacity : 6 x 500 mL Size (Ø x H) : $\varnothing 336 \times 179$ mm Max. height for tube fit : 168.5 mm Incl. a coupling bolt lid</p>	500mL Flat	-	70 x 141 158.7	10,000 17,743	
	250mL Flat	TR250(500A)	62 x 100 158.7	10,000 15,540	

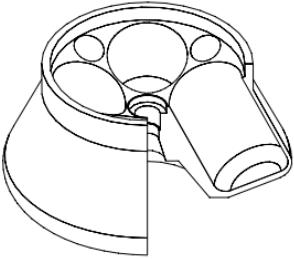
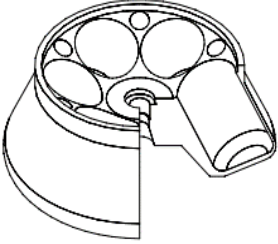
Rotor		Tube Capacity /Bottom Type	Required Adaptor	Bore Ø x L Radius(mm)	Max. RPM (rpm) Max. RCF (xg)
 <p>A1000-4</p> <p>Hole angle : $\angle 25^\circ$ Max. Capacity : 4 x 1,000 mL Size (\varnothing x H) : $\varnothing 350$ x 196 mm Max. height for tube fit : 184.8 mm Incl. a coupling bolt lid</p>	1000mL Flat	-	98 x 144 169.9	8,000 12,157	
	500mL Flat	TR500(1000)	69 x 149 155.7	8,000 11,141	
	250mL Flat	TR250(1000)	62 x 109 136.4	8,000 9,760	
 <p>A1000-6</p> <p>Hole angle : $\angle 25^\circ$ Max. Capacity : 6 x 1,000 mL Size (\varnothing x H) : $\varnothing 408$ x 188 mm Max. height for tube fit : 176.5 mm Incl. a coupling bolt lid</p>	1000mL Flat	-	98 x 144 200.1	7,000 10,962	
	500mL Flat	TR500(1000)	69 x 149 185.9	7,000 10,184	
	250mL Flat	TR250(1000)	62 x 109 166.6	7,000 9,127	



RECYCLABLE

hanil